

CM-GRIDS (URBAN)
Chief Minister - Green Road
Infrastructure Development Scheme
(Urban)



Urban Development Department
Government of Uttar Pradesh
Ref No.: RFP NIT No. - 133/CE/24-25

Kanpur Municipal Corporation

Government of Uttar Pradesh (GoUP)



This page has been intentionally left blank

REQUEST FOR PROPOSAL (RFP)
for
Construction of Integrated Roads with 5
Years Maintenance



Uttar Pradesh

RFP DOCUMENT
{June}, 2024

{Kanpur Municipal Corporation}

INVITATION FOR BID (IFB)

Office of Municipal Commissioner,
Kanpur Municipal corporation
E-Procurement Tender Notice

NIT No. 133/CE/24-25.

Date: 25/06/2024

Chief Engineer, Kanpur Municipal Corporation **invites** percentage-rate bids on <http://etender.up.nic.in> from eligible bidders for the following package under the CM-GRID Scheme.

Sl. No.	Nagar Nigam	Package No.	Included Roads	Length of Road (Km)	Estimated Cost Excluding GST (Rs. Lakh)		Total Estimated Cost of Work (Rs. In Lakh)	Earnest Money Deposit (Rs. in Lakh)	Duration of Construction Work (in Months)	Tender Fee Including GST
					Construction	Maintenance For 5 Years				
1	2	3	4	5	6	7	8	9	10	11
1	Kanpur Municipal Corporation	KMC/C MG 01	Work of widening and strengthening of the stretch from NH 19 via Rajaram Intersection to Hamirpur main road (4.30 KM) in front of Namak Factory Intersection, Under Zone-02	4.30	3863.91	49.83	3913.74	50	15	48542.13
2	Kanpur Municipal Corporation	KMC/C MG 02	Work of widening and strengthening of the stretch from Karahi Road to Hamirpur Road metro line via Rambagh Tiraha (6.05 KM) Under Zone -03	6.05	5894.40	66.75	5961.15	58.94	15	72702

3	Kanpur Municipal Corporation	KMC/C MG 03	Work of widening and strengthening of the stretch from Baba Kuti intersection to Alankar Guest House (Length 2.34 km) via Sote Baba Mandir is being carried out, Under Zone -03	2.34	1956.48	19.80	1976.28	30.81	15	25447
4	Kanpur Municipal Corporation	KMC/C MG 04	Work of widening and strengthening of the stretch (1.15 km) from Bagiya Crossing Kalyanpur to Kesa Office under is being carried out Under Zone -06	1.15	1069.19	15.03	1084.22	21.68	12	15154.00

The details can be seen on <http://etender.up.nic.in> w.e.f. 25.06.2024.

Chief Engineer,
kanpur Municipal Corporation

नगर निगम कानपुर

ई-प्रोक्थोरमेन्ट निविदा सूचना

पत्रांक : 133/CE/24-25

दिनांक 25/06/2024

मुख्य अभियन्ता नगर निगम कानपुर की ओर से प्रतिषत दर पर सीएम-ग्रिड योजनान्तर्गत पात्र निविदाताओं से निम्न पैकेज हेतु ऑनलाइन निविदायें <http://etender.up.nic.in> आमंत्रित की जाती हैं।

क्र. सं.	नगर निगम	पैकेज सं.	अन्तर्निहित मार्ग	मार्ग की लम्बाई (Km)	अनुमानित लागत जीएसटी रहित (रु० लाख में)		कार्य की सम्पूर्ण अनुमानित लागत (रु० लाख में)	निर्माण धरोहर धनराशि (लाख रु० में)	कार्य पूर्ण करने की अवधि (माह में)	निविदा प्रपत्र का मूल्य जी०एस० टी० सहित
					निर्माण	5 सालों का अनुरक्षण				
1	2	3	4	5	6	7	8	9	10	11
1	नगर निगम कानपुर	KMC /CM G 01	जोन 02 के अन्तर्गत एन०एच० 19 से राजाराम चौराहा होते हुये नमक फैक्ट्री चौराहे के सामने हमीरपुर मुख्य मार्ग तक ल० 4.30 कि०मी० के चौड़करण सुदृढीकरण का कार्य	4.30	3863.91	49.83	3913.74	50	15	48542.13
2	नगर निगम कानपुर	KMC /CM G 02	जोन -3 के अन्तर्गत बर्बा बाई पास करही रोड राम बाग तिराहा होते हुये हमीरपुर मुख्य मार्ग मेट्रो लाइन तक ल० 6.05 कि०मी० के चौड़करण सुदृढीकरण का कार्य	6.05	5894.40	66.75	5961.15	58.94	15	72702
3	नगर निगम कानपुर	KMC /CM G 03	जोन-03 के अन्तर्गत बाबा कुटी चौराहे से सोटे बाबा मन्दिर होते हुये अंलकार गेस्ट हाउस तक ल० 2.34 कि०मी० के चौड़करण सुदृढीकरण का कार्य	2.34	1956.48	19.80	1976.28	30.81	15	25447
4	नगर निगम कानपुर	KMC /CM G 04	जोन-06 के अन्तर्गत बगिया क्रासिंग कल्यानपुर से केसा कार्यालय तक तक ल० 1.15 कि०मी० के चौड़करण सुदृढीकरण का कार्य	1.15	1069.19	15.03	1084.22	21.68	12	15154.00

निविदा से सम्बन्धित नियम/शर्तें तथा विवरण <http://etender.up.nic.in> पर दिनांक 25.06.2024 से देखी जा सकती है।

मुख्य अभियन्ता
नगर निगम कानपुर

Office of Municipal Commissioner,
Kanpur Municipal corporation

Condition for Notice Inviting Tenders

NIT No. 133/CE/24-25

Dated -25/06/24

E-Procurement

- 1) **Chief Engineer of Kanpur Municipal Corporation** on-line percentage-rate bids from the eligible Contractors for the following work including five (5) years maintenance under CM-GRID Scheme. The bidders shall be registered with UPPWD in class (A) for road works or equivalent class and category in n Kanpur Municipal Corporation/CPWD/MES/Railways and other State Govt. and Central Govt. Departments. The Bidder who is not registered as mentioned above may submit the bid, subject to submission of all documents required for registration in the relevant class and categories in Nagar Nigam as per guidelines/Circular संख्या - 8/2017/836/23-7-17-176 (सा0) /06 दिनांक 08 जून 2017, तक0 सेल/07 /निदे0/2019 दिनांक 28 जून 2019, संख्या - 3890/नौ-5-19-149सा/2019 दिनांक 20 सितम्बर. Such bidder shall have to get registered in Kanpur Municipal Corporation before award of contract. The Bidder may submit bids for any or all the works as specified in SBD. Bidders are advised to note the eligibility criteria specified in Instruction to Bidders (ITB) and other sections of Standard Bidding Document (SBD) to qualify for the award of the contract. Bidders shall submit their bid on e-tender portal i.e. <http://etender.up.nic.in>

Sl. No.	Nagar Nigam	Package No.	Included Roads	Length of Road (Km)	Estimated Cost Excluding GST (Rs. Lakh)		Total Estimated Cost of Work (Rs. In Lakh)	Earnest Money Deposit* (Rs. in Lakh)	Duration of Construction Work (in Months)	Tender Fee Including GST
					Construction	Maintenance For 5 Years				
1	2	3	4	5	6	7	8	9	10	11
1	Kanpur Municipal Corporation	KMC /CM G 03	Work of widening and strengthening of the stretch from Baba Kutu intersection to Alankar Guest House (Length 2.34 km) via Sote Baba Mandir is being carried out, Under Zone -03	2.34	1956.48	19.80	1976.28	30.81	15	25447

- * (i) Up to Rs. 20 Cr. value of work - 2.0% (subjected to maximum of Rs. 30 Lakh).
- (ii) Rs. 20 to 50 Cr. value of work - 1.5% (subjected to maximum of Rs. 50 Lakh).
- (iii) Above Rs. 50 Cr. value of work - 1.0%

Note: Bid Security will be a fixed sum rounded off to the nearest ten thousand Rupees.

- 2) Bidders are advised to visit the project sites of the work and physically assess the activities (including geographical & geological aspects) which are involved for completing the work including the quantum of work besides the information supplied in the tender document. No claim whatsoever shall be entertained on this account.
- 3) Time allowed for completion of whole work is **as per column no. 10** (as above), including rainy season.
- 4) The bids shall remain valid for acceptance for a period of **120 days** from the last date of submission of bids. Bids once submitted cannot be withdrawn.
- 5) The Bidders need to submit Earnest Money Deposit (EMD) and Tender Document fee (including GST) as shown in **column no. – 9 & 11** of the table (as above). It is mandatory for the bidders to submit the proposal as per letter no. 317/ Twenty-7-2018-176b/2006 TC-1 Dated 10-04-2019 and receipt must be submitted. A set of bidding document will be available online on website <http://etender.up.nic.in>
- 6) **Availability of Bid Document and mode of submission:** The bidders need to submit the proposal online through website <http://etender.up.nic.in> . No other mode for submission of bid will be accepted.
Note: - The bidder would be required to register in the website <http://etender.up.nic.in> which is **free of cost**. For submission of bids, the bidder is required to have valid Digital Signature Certificate (DSC).
- 7) A pre-bid meeting shall be held in the office or through online mode by the Authority at the address and date as mentioned in the Appendix to ITB for the work to clarify the issues and to answer questions on any matter that may raised, latest by 2nd July'24 on chiefengineernagarnigam@gmail.com with copy to urida.goup@gmail.com.
- 8) Bids must be submitted online between **12:00 PM on date 29.06.2024 to 03: 00 PM of date 06.08.2024** and the technical bids will be opened online on **date.06.08.2024 at 04: 00 PM**. If the office happens to be closed on the date of opening of the bids as specified,

the bids will be opened online on the next working day respectively, at the same time and validity of bid will be considered from the original date. The date and time of opening of the financial bid shall be notified on website <http://etender.up.nic.in> . The Financial bids shall be accordingly opened online.

- 9) A bidder shall not be permitted to bid for works in the Kanpur Municipal Corporation for award and execution of contracts in which his or his spouse's near relatives (defined as first blood relations, and their spouses) is posted as an officer in any capacity between the grades of Chief Engineer and Junior Engineer (both inclusive).
- 10) No Engineer of Gazetted rank or other Gazetted officer employed in Engineering or Administrative duties in an Engineering Department of the State/Central Government is allowed to work as a Contractor for a period of two years after his retirement from Government service, without Government permission. This contract is liable to be canceled if either the Contractor or any of his employees is found any time to be such a person who had not obtained the aforesaid permission of the Government before submission of the tender or engagement in the Contractor's service.
- 11) Bid documents and other details consisting of qualification information and eligibility criteria of bidders, plans, specifications, drawings, the schedule of quantities of the various works and the set of terms & conditions of contract to be complied with by the bidder can be seen on the e-tender portal <http://etender.up.nic.in>.
- 12) Bidders may bid for any one or more of the works mentioned in the table above. To qualify for a package of contracts made up of this and other contracts for which bids are invited in the same NIT, the bidder must demonstrate having experience and resources sufficient to meet the aggregate of the qualifying criteria for the individual contracts.
- 13) Other details can be seen in the bidding documents. The Employer/TIA shall not be held liable for any delays due to system failure beyond its control. Even though the system will attempt to notify the bidders of any bid updates, the Employer shall not be liable for any information not received by the bidder. It is the bidders' responsibility to verify the website for the latest information related to the tender.
- 14) Any bidder who is blacklisted in any Government Department or punished by any Hon'ble court for criminal activity is not allowed to participate in the bidding process or involved in the organised crime or gangster activities or Mafia or Gunda or Anti-Social activities is

strictly prohibited to participate in the bidding process. If it is established at any time that any bidder has been blacklisted or has criminal record, his bid/Contract shall be automatically cancelled.

- 15) As per UP State Government Order, any Bidder who is an Advocate and registered with any Bar Council shall not be allowed to participate in the bidding. If it is established that the Contractor is registered with any bar council, his bid/Contract shall be automatically cancelled.
- 16) In any one phase of the CM GRID scheme, a bidder will not bid for more than three bids in the state of Uttar Pradesh.
- 17) Bidder must submit all information's / documents on prescribed proforma (form T-4, T-5, T-6) with each bid on a non-judicial stamp paper of Rs. 100/- giving all information on the prescribed Proforma mentioned in this SBD.
- 18) Bidder has to provide extra performance security at the time of making bond of percentage below bid in compliance of GO 622/23-12-2012-2 AUDIT/08TC-2 Dated 08.06.2012 as per rule as below: -
 - a. Up to 10 % below rate on BOQ @ 0.50% per 1% below rate.
 - b. In case of bidder quotes rates more than 10% below on BOQ than bidder has to provide extra performance security as above and @ 1% per 1% below rates over 10% below rates.
- 19) Defect Liability Period is for five years calculated from actual date of completion. Payment of maintenance shall be performance based as per Annexure-IV. The year wise breakup of maintenance costs shall be given at later stage.
- 20) The Bidder shall be responsible for executing the entire works i.e. civil work, electrical work, water supply and sanitary works etc. For executing the street lightning electrical works, water supply and sanitary works the Bidder will have to comply as per relevant clause of Section-2.
- 21) The Bidder might encounter underground utilities services for which necessary provision for diversion and its restoration is to be done.
- 22) The Bidder shall be responsible to make every effort to minimize the breakages, losses and wastage during erection & construction of the Purchaser-supplied items including electrical works.

- 23) The Bidder shall make sufficient arrangements for safety during construction to pass the traffic without any obstruction. If any incident/accident occurred during execution of work, then the contractor shall be liable for the same.
- 24) The Bidder shall make sufficient arrangement for environmental compliances such as **suppression of dust, optimize use of construction material, reduction of waste material, etc. during the construction period.**
- 25) Materials such as cement, reinforcement steel, bitumen and emulsion should be procured from approved vendor list (First four vendors only) as indicated in NHAI office memorandum issued vide letter no. NHAI/TIC/PQ/2012-13/205 dated 19.10.2022.
- 26) The job mix design for various items of work wherever needed, shall be the sole responsibility and liability of contractor. The job mix design shall have got done from reputed institutions like IITs/NITs/CRRRI and the report shall be submitted to employer within 30 days of the date of start of work.
- 27) The responsibility for any losses due to defects lies with the Contractor. The Contractor will be responsible for the losses incurred and same shall be recovered from the Contractor bills/any security deposit.
- 28) The Contractor is advised to visit the site and get any investigation done at his own, while preparing the Bid.
- 29) Remaining conditions as prescribed in bidding documents shall be binding on the Contractor.
- 30) The language for any formal correspondences can be in English as well as in Hindi.
- 31) Standard Operating Procedure (SOP) and maintenance manual for maintenance works shall be circulated separately.
- 32) Bidder has to provide a pledge/undertaking as an Integrity Pact for ensuring quality works and not to resort to any corrupt practices in any aspect/stage of the Contract.
- 33) GST will be applicable as per prevailing laws. (**All civil construction items rate in BOQ are without GST and Electrical Utility shifting items rate are with GST.**)
- 34) 1% Labor cess will be deducted from the Contractor Bill.
- 35) All other statutory deductions as per Government norms/prevaling laws will be applied.

Contents

INVITATION FOR BID (IFB)	3
E-Procurement Tender Notice	4
ई-प्रोक्योरमेन्ट निविदा सूचना	5
Condition for Notice Inviting Tenders	6
SECTION 1: - INSTRUCTION TO BIDDER (ITB)	17
1. Scope of Bid	19
2. Source of Funds	19
3. Eligible Bidders	19
4. Qualification of the Bidder	21
5. One Bid per Bidder	28
6. Cost of Bidding	29
7. Site Visit	29
B. BIDDING DOCUMENTS	30
8. Content of Bidding Documents	30
9. Clarification of Bidding Documents	30
10. Amendment of Bidding Documents	31
C. PREPARATION OF BIDS	31
11. Language of the Bid	31
12. Documents Comprising the Bid	31
13. Bid Prices	32
14. Currencies of Bid and Payment	32
15. Bid Validity	32
16. Bid Security/Earnest Money Deposit (EMD)	33
17. Alternative Proposals by Bidders	33
18. Format and Signing of Bid	34
D. SUBMISSION OF BIDS	34
19. Electronic Submission of Bids	34
20. Deadline for Submission of the Bids	34
21. Late Bids	35
22. Modification and Withdrawal of Bids	35
E. BID OPENING AND EVALUATION	35
23. Bid Opening	35
24. Process to be Confidential	36
25. Clarification of Financial Bids	36

26.	Examination of Bids and Determination of Responsiveness	36
27.	Deleted.	37
28.	Deleted.	37
29.	Evaluation and Comparison of Financial Bids	37
30.	Deleted	38
F.	AWARD OF CONTRACT	38
31.	Award Criteria	38
32.	Employer's Right to Accept any Bid and to Reject any or all Bids	38
33.	Notification of Award and Signing of Agreement	38
34.	Performance Security	39
35.	Advance Payment and Security	39
36.	Dispute Review Expert	39
37.	Corrupt or Fraudulent Practices	39
	Appendix to ITB	40
	ANNEXURE-I	41
	ANNEXURE-II	43
	ANNEXURE III	45
	SECTION 2: - QUALIFICATION INFORMATION	47
	TECHNICAL EVALUATION	54
	FORM T-1 B	55
	FORMAT FOR EVIDENCE OF ACCESS TO OR AVAILABILITY OF CREDIT FACILITIES	56
	AFFIDAVIT (Non-Blacklisting & Non- Rescind/abandon)	57
	UNDERTAKING (Cash investment)	58
	UNDERTAKING (for Green Technologies) {Cl 4.4.A.b, Section I}	59
	SECTION 3:- CONDITIONS OF CONTRACT	67
A.	GENERAL CONDITION OF CONTRACT	68
1.	Definitions	68
2.	Interpretation	70
3.	Language and Law	71
4.	Engineer's Decisions	71
5.	Delegation	71
6.	Communications	71
7.	Sub-contracting	71
8.	Other Contractors	71
9.	Personnel	72

10.	Employer's and Contractor's Risks	72
11.	Employer's Risks	72
12.	Contractor's Risks	72
13.	Insurance (Contractors All Risk Policy)	72
14.	Site Investigation Reports	73
15.	Queries about the Contract Data	73
16.	Contractor to Construct the Works	73
17.	The Works to be completed by the Intended Completion Date	73
18.	Approval by the Engineer	73
19.	Safety	74
20.	Discoveries	74
21.	Possession of the Site	74
22.	Access to the Site	74
23.	Instructions	74
24.	Disputes	74
25.	Procedure for Disputes	74
26.	Replacement of Dispute Review Expert	74
B. TIME CONTROL		75
27.	Programme	75
28.	Extension of the Intended Completion Date	75
29.	Deleted.	76
30.	Delays Ordered by the Engineer	76
31.	Management Meetings	77
32.	Early Warning	77
C. QUALITY CONTROL		77
33.	Identifying Defects	77
34.	Tests	77
35.	Correction of Defects	78
36.	Uncorrected Defects	79
D. COST CONTROL		79
37.	Bill of Quantities	79
38.	Changes in the Quantities	79
39.	Variations	79
40.	Payments for Variations	80
41.	Cash Flow Forecasts	80

42.	Payment Certificates	80
43.	Payments	83
44.	Compensation Events	83
45.	Tax	84
46.	Currencies	84
47.	Price Adjustment	84
49.	Liquidated Damages	85
50.	Deleted.	86
51.	Advance Payment	86
52.	Securities	86
53.	Deleted.	86
54.	Cost of Repairs	86
E. FINISHING THE CONTRACT		87
55.	Completion	87
56.	Taking Over	87
57.	Final Account	87
58.	Operating and Maintenance Manuals	87
59.	Termination	87
60.	Payment upon Termination	88
61.	Property	89
62.	Release from Performance	89
F. SPECIAL CONDITIONS OF CONTRACT		89
63.	Labour	89
64.	Compliance with Labour Regulations:	89
65.	Provision of vehicle	92
66.	Drawings and Photographs of the Works	92
67.	Green technologies	92
SECTION 4:- CONTRACT DATA		97
CONTRACT DATA		98
SECTION 5:- SCOPE OF WORK & TECHNICAL SPECIFICATION		105
1.	Project Background	106
2.	Scope of Work	106
A.	Road, Footpath and Allied works	108
B.	Proposed Road Network	108
C.	Scope of work for utility provision	108

D. 119E. 110	Pre Construction Stage	
F. Construction Phase		111
G. Post Construction Phase		112
H. Safety, vehicle breakdowns and accidents		114
I. 124J. Drawings Design	Details of Roads in 124K.	115
SECTION 6:- FORM OF BID		117
FORM OF BID		118
SECTION 7:- BILL OF QUANTITIES		121
SECTION 8:- SECURITIES AND OTHER FORMS		127
BID SECURITY BANK GUARANTEE		128
UNDERTAKING		129
PERFORMANCE BANK GUARANTEE		130
INDENTURE FOR SECURED ADVANCES		132
Issue of Notice to proceed with the work		135
Agreement Form		136
SECTION 9:- DRAWINGS		139
SECTION 10:- DOCUMENTS TO BE FURNISHED BY BIDDER		141

THIS PAGE HAS BEEN INTENTIONALLY KEPT BLANK

SECTION 1: - INSTRUCTION TO BIDDER (ITB)

Table of Clauses

Clause	Description	Clause	Description
A	General	D	Submission of Bids
1	Scope of Bid	19	Electronic Submission of Bids
2	Source of Funds	20	Deadline for Submissions of Bids
3	Eligible Bidders	21	Late Bids
4	Qualifications of Bidder	22	Modification and Withdrawal of Bids
5	One Bid per Bidder	23	Bid opening
6	Cost of Bidding	24	Process to be Confidential
7	Site Visit	25	Clarification of Bids and Contracting the Employer
B	Bidding Documents and Evaluation	26	Examination of bids and Determination of Responsiveness
8	Content of Bidding Documents	27	
9	Clarification of Bidding Documents	28	
10	Amendment of Bidding Documents	29	Evaluation and Comparison of Bids
C	Preparation of Bids	30	
11	Language of Bid	F	Award of Contract
12	Documents Comprising the Bid	31	Award Criteria
13	Bid Prices	32	Employer's Right to Accept any Bid and to Reject any or all Bids
14	Currencies of Bid and Payment	33	Notification of Award
15	Bid Validity	34	Performance Security
16	Earnest Money	35	Advance Payment and Security
17	Alternative Proposals by Bidders	36	Dispute Review Expert
18	Format and Signing of Bid	37	Corrupt or Fraudulent Practices

A. GENERAL

1. Scope of Bid

- 1.1 The Employer/Authority (named in Appendix to ITB) invites bids for the construction of works (as defined in these documents and referred to as "the works") detailed in the table given in IFB. The bidders may submit bids for any or all of the works detailed in the table given in IFB.
- 1.2 The successful Bidder will be expected to complete the Works by the Intended Completion Date specified in Section 3-Conditions of Contract and maintenance for 5 years from the date of completion as per SOP and maintenance manual.
- 1.3 Throughout these documents, the terms "bid" and "tender" and their derivatives (bidder/ tenderer, bid/ tender, bidding/ tendering, etc.) are synonymous.

2. Source of Funds

- 2.1. The expenditure on this project will be met from the budget of Govt. of U.P.

3. Eligible Bidders

- 3.1 This Invitation for Bids is open to all bidders.
 - a) A Bidder bidding individually or as a member of a Joint Venture (JV) shall not be entitled to submit another Bid either individually or as a Member of any Joint Venture (JV), as the case maybe;
 - b) The term Bidder used herein would apply to both a single entity and a Joint Venture;
 - c) The Bidder shall be legally competent to enter into an Agreement as per prevailing Indian law;
 - d) A Bidder shall not have a conflict of interest (the "**Conflict of Interest**") that affects the Bidding Process. Any Bidder found to have a Conflict of Interest shall be disqualified. A Bidder shall be deemed to have a Conflict of Interest affecting the Bidding Process, if:
 - i. the Bidder have common controlling shareholders or other ownership interest in the other Bidder;
 - ii. A constituent of such Bidder is also a constituent of another Bidder; or
 - iii. Such Bidder receives or has received any direct or indirect subsidy or grant from any other Bidder; or
 - iv. Such Bidder has the same legal representative for purposes of this Bid as any other Bidder; or
 - v. Such Bidder has a relationship with another Bidder, directly or through common third parties, that puts them in a position to have access to each other's information about, or to influence the Bid of either or each of the

- other Bidder; or
- vi. Such Bidder (including its member or any shareholder thereof) possessing over 25% of the paid up and subscribed capital in its own company, also holds more than 25% of the paid up and subscribed equity capital in the other Bidder and its Member of such other Bidder;
 - vii. The Bidder has employed the current employee/s of the Tender Inviting Authority (TIA); or any close relatives of the Bidder currently employed by the TIA, whether on a permanent or contract basis;
 - viii. Any of its affiliates participated as a consultant in the preparation of the design or technical specifications of the works that are the subject of the Bid; or
 - ix. Any of its affiliates has been hired (or is proposed to be hired) by the Employer as Project Manager for the Contract implementation;
 - x. Would be providing goods, works, or non-consulting services resulting from or directly related to consulting services for the preparation or implementation of the project specified in the RFP that it provided or were provided by any affiliate that directly or indirectly controls, is controlled by, or is under common control with that firm;
 - xi. A Bidder shall be liable for disqualification if any legal, financial or technical adviser of the Employer in relation to the Project is engaged by the Bidder, or any of its Members, as the case may be, in any manner for matters related to or incidental to the Project. For the avoidance of doubt, this disqualification shall not apply where such adviser was engaged by the Bidder, its Member in the past but its assignment expired or was terminated 6(six) months prior to the date of issue of this RFP.

- 3.2 All bidders shall provide in Section 2, Forms of Bid and Qualification Information, a statement that the Bidder is neither associated, nor has been associated, directly or indirectly, with the Consultant or any other entity that has prepared the design, specifications, and other documents for the Project or being proposed as Project Manager for the Contract. A firm that has been engaged by the Employer to provide consulting services for the preparation or supervision of the works, and any of its affiliates, shall not be eligible to bid.
- 3.3 The Bidder shall not have been blacklisted by any Government Agency, or proved to have indulged in serious fraudulent practices by a Court of Law or an independent Commission of Inquiry in India or abroad at the time of Bid Due Date.
- 3.4 Bidders should have valid PAN card and GST registration in India.
- 3.5 Bidders should have registered office in India which is operational for at least three-year preceding bid submission due date.
- 3.6 The Authority requires that the bidders / contractors observe the highest standard of ethics during the procurement and execution of such contracts and at all times hold the Authority's interest paramount, avoid conflicts with other assignments or its own interests, and act without any consideration for future work. The Agency shall not accept or engage in any assignment that would be in conflict with its prior

or current obligations to other clients, or that may place it in a position of not being able to carry out the assignment in the best interests of the Authority.

4. Qualification of the Bidder

4.1 All bidders shall provide in **Section 2**, Forms of Bid and Qualification Information, a preliminary description of the proposed work method and schedule, including drawings and charts, as necessary. The proposed methodology should include a programme of construction backed with equipment planning and deployment duly supported with broad calculations and quality assurance procedures proposed to be adopted justifying their capability of execution and completion of work as per technical specifications, within stipulated period of completion.

4.2 Deleted.

4.3 All bidders shall include the following information and documents with their bids in Section 2:

- a. copies of original documents defining the constitution or legal status, place of registration, and principal place of business; written power of attorney of the signatory of the Bid to commit the Bidder;
- b. total monetary value of construction work performed for each of the last five years;
- c. experience in works of a similar nature (at least one similar works of the Lead Bidder). and size for each of the last five years (Similar Works defined in Clause 4.5 A below) and details of works underway or contractually committed along with the details of clients who may be contacted for further information on those contracts;
- d. evidence of ownership of major items of construction equipment as per requirement in the construction of road, evidence of arrangement of possessing them on hire/lease/buying as defined therein;
- e. details of the technical personnel proposed to be employed for the Contract having the qualifications defined in Annexure II;
- f. reports on the financial standing of the Bidder, such as profit and loss statements and auditor's reports for the past five years duly certified by the registered chartered accountant;
- g. evidence of access to line(s) of credit and availability of other financial resources facilities (10% of contract value), certified by the Bankers (not more than 3 months old);
- h. undertaking that the bidder will be able to invest a minimum cash upto 25% of contract value of work, during the implementation of work;
- i. authority to seek references from the Bidder's bankers;

- j. information regarding any litigation, current or during the last five years, in which the Bidder is involved, the parties concerned, and the disputed amount;
- k. proposals for subcontracting components of the Works amounting to 25 per cent of the Bid Price (for each, the qualifications and experience of the identified sub- contractor in the relevant field should be annexed);
- l. the proposed methodology and programme of construction, backed with equipment planning and deployment, duly supported with broad calculations and quality control procedures proposed to be adopted, justifying their capability of execution and completion of the work as per technical specifications within the stipulated period of completion as per milestones;
- m. Deleted;
- n. the Bidder shall have a positive net worth for the Five financial years as mentioned in section 2;
- o. the contractor has to show all the ongoing work all over the country as mentioned in section 2; and
- p. the contractor should submit the all affidavit(s) as mentioned in Section 2.
- q. **The Bidder must submit the Package p7references in case of applied for more than one package.**

4.4. The Joint Ventures (JV) are allowed for package size exceeding Rs. 50 crores:

Bids submitted by a Joint Venture (JV) of not more than three firms as partners shall comply with the following requirements:

- (a) There shall be a Joint Venture Agreement (Refer Annexure III to ITB) specific for these contract package(s) between the constituent firms, indicating clearly, amongst other things, the proposed distribution of responsibilities both financial as well as technical for execution of the work amongst them. For the purpose of this clause, the most experienced lead partner will be the one defined. A copy of the Joint Venture agreement in accordance with requirements mentioned in Annexure – III; shall be submitted before any award of work could be finalized.
- (b) The bid, and in the case of the successful bidder, the Form of Agreement, etc., shall be signed and / or executed in such a manner as may be required for making it legally binding on all partners (including operative parts of the ensuing Contract in respect of Agreement of Arbitration, etc.). On award of work, the

Form of Agreement and Contract Documents shall be signed by all partners of the Joint Venture to conclude Contract Agreement.

- (c) Lead partner shall be nominated as being partner-in-charge; and this authorization shall be evidenced by submitting a power of attorney signed by the legally authorized signatories of all the partner.
- (d) The partner-in-charge shall be authorized to incur liabilities and to receive instructions for and on behalf of the partners of the Joint Venture, whether jointly or severally, and entire execution of the Contract (including payment) shall be carried out exclusively through the partner-in-charge. A copy of the said authorization shall be furnished in this Bid.
- (e) All partners of the Joint Venture shall be liable jointly and severally for the execution of the Contract in accordance with the Contract terms, and a relevant statement to this effect shall be included in the authorization mentioned under sub clause (c) above as well as in the Form of Tender and the Form of Agreement (in case of a successful bidder).
- (f) In the event of default by any partner, in the execution of his part of Contract, the Employer shall be so notified within 30 days by the partner-in-charge, or in the case of the partner-in-charge being the defaulter, by the partner nominated as partner-in-charge of the remaining Joint Venture. The partner-in-charge shall, within 60 days of the said notice, assign the work of the defaulting partner to any other equally competent party acceptable to the Employer to ensure the execution of that part of the Contract, as envisaged at the time of bid. Failure to comply with the above provisions will make the Contractor liable for action by the Employer under the Conditions of Contract. If the Most Experienced i.e. Lead Partner defined as such in the Communication approving the qualification defaults, it shall be construed as default of the Contractor and Employer/Authority will take action under the Conditions of Contract
- (g) Notwithstanding the permission to assigning the responsibilities of the defaulting partner to any other equally competent party acceptable to the Employer as mentioned in sub clause (f) above, all the partners of the Joint Venture will retain the full and undivided responsibility for the performance of their obligations under the Contract and/ or for satisfactory completion of the Works.
- (h) The bid submitted shall include all the relevant information as required under the provisions of Sub-Clause 4.5 of ITB and furnished separately for each partner.

- (i) All partners of the joint venture (including prime contractor and 2nd/3rd partner) should be available at the project office for day to day execution, monitoring and meetings for timely completion of the project.

4.5. A. The bidder shall meet the following minimum Criteria

- (a) Average annual turnover (defined as billing for works in progress and completed in all classes of civil engineering construction work only) over the last five years equal to estimated cost of work (excluding maintenance).
- (b) Experience: Contractor must have successfully completed or substantially completed similar works during last five years ending last day of month previous (i.e. 31.05.2024) to the one in which applications are invited should be either of the following .

Similar work is defined as, experience in substantial completion of construction of roads in urban areas that includes carriageway, footpaths, streetlights and underground utilities as below:

- Carriageway works should include asphalt/ cement concrete surface with necessary base layers.
- Footpath works include road works involving paver blocks/kerb stone or concrete pathways with roadside landscapes and likewise.
- Underground utilities work, which includes gas, power, sewer, water supply, storm water and telecom works.
 - For Power lines, the Contractor should have similar experience of shifting of power lines from overhead to underground with a minimum capacity of 11KV.

For the work(s) being submitted for consideration as 'similar work experience' **the Bidder must obtain 80 marks out of 100** for the qualification as mentioned in technical evaluation in Section 2 and accordingly a financial proposal will be opened for those who qualifies.

In case the Bidder is having / not having prior experience in Green Technologies as mentioned in Special Condition of Contracts **Cl. 67** (Section 3) the bidder can provide undertaking as mentioned in Section 2.

All eligible projects for claiming experience should have been executed for Central/State Government departments (or) Central/State Autonomous Bodies (or) Central/State Public Sector.

The Completion certificate shall be signed by the Engineer in charge, not below the rank of an Executive Engineer or equivalent.

Documentary evidence for project credentials like, work order or purchase order or completion certificate or letter of appointment should be submitted. Actual Completion Date and Actual Completion cost as indicated in the completion certificate issued by the Authority shall be considered for the evaluation.

- (c) The works may have been executed by the bidder as prime contractor or as a member of a joint venture or approved sub-contractor. As subcontractor, the firm should have acquired the experience of execution of all major items of works under the proposed contract. In case a project has been executed by a joint venture, weightage towards experience of the project would be given to each joint venture in proportion to their participation in the joint venture.

Substantially completed works means those works which are at least 90% completed as on the date of submission (i.e. gross value of work done up to the last date of submission is 90% or more of the original contract price) and continuing satisfactorily.

For these, a certificate from the Employer/Engineer not below the rank of an Executive Engineer or equivalent shall be submitted along with the application incorporating clearly the name of the work, Contract value, billing amount, date of commencement of works, satisfactory performance of the Contractor and any other relevant information.

- (d) The contractor or his identified sub-contractor should possess Class A registration and required valid electrical line license (issued from Directorate of Electrical Safety Department and Uttar Pradesh Power Corporation Limited (UPPCL)) including five years old for executing the street light electrification works and should also have executed underground electrification works (power) for a minimum amount as specified in 4.5A (b).
- (e) The contractor/bidder or his identified sub-contractor should possess the required valid license for executing the water supply/sanitary engineering works and should have executed similar water supply/sanitary engineering works for a minimum amount as indicated in Appendix in any one financial year (at least in last three years).
- (f) Deleted.

B. Each bidder should further demonstrate

- a. Availability for construction either owned, or on lease or hire, of the key equipment states in Annexure I including equipment required for establishing field laboratory to perform mandatory test, and the stated in the Annexure I.

The bidder should own or should have assured ownership to the following key items of equipment, in full working order, and must demonstrate that, based on known commitments they will be available for use in the proposed contract.

Based on the studies, carried out by the Engineer, the minimum requirement of major equipment to attain the completion of works in accordance with the prescribed construction schedule are shown in the **Annexure-I**.

- b. The bidder must have suitably qualified personnel to fill the positions as per **Annexure-II**. The bidder will supply information on a prime candidate and an

alternate for each position, both of whom should meet the experience requirements specified in Annexure-II.

- c. The bidder should demonstrate that he has access to, or has available, liquid assets (aggregate of working capital, cash in hand and uncommitted bank guarantees) and/or credit facilities of not less than 10% of the value of the contract/contracts applied for certified by the Bankers (Not more than 3 months old) (Construction cash flow may be taken as 25% of the estimated value of contract/contracts).
 - d. The audited balance sheets for the last five years should be submitted, which must demonstrate the soundness of the bidder's financial position, showing long term profitability including an estimated financial projection for the next two years. If necessary, the Employer will make enquiries with the bidder's bankers.
 - e. The Bidder shall have a positive net worth for the last Five financial years as mentioned in section 2.
- C.** To qualify for more than one contract/package, the bidder must demonstrate having experience and resources sufficient to meet the aggregate of the qualification criteria for each contract given in clauses [Cl.4.5.B(a)], [Cl.4.5B(b)], [Cl.4.5B(c)] and Cl. 4.7.
- D.** To qualify for a package of contracts made up of this and other contracts for which bids are invited in the Notice Inviting Tender, the bidder must demonstrate having experience and resources sufficient to meet the aggregate of the qualifying criteria for the individual contracts.

As per Operation Manual

Important: - If any bidder is bidding more than one package/contract in the Notice Inviting Tender the bidder must inform to the Tender Inviting Authority at the time or before the opening of technical bid about one of the following two options failing which the Tender Inviting Authority will act for Option 2.

Option 1: Bidders may be asked to indicate in each technical bid the order of opening of their bids, so that the financial offers corresponding to the qualifying technical bids are opened in that order of his Assessed Available Bid Capacity is exhausted. Remaining financial offers of the bidder will be kept unopened.

Option 2: Financial bids of all qualifying bidders may be opened, and bids arranged in order with that package where the difference between potential L-1 and potential L-2 is the greatest followed by the one in which it is

next greatest and so on. L-1 will be awarded packages till his bid capacity is exhausted. The process will be repeated for the remaining packages based on differences between earlier potential L-2 (now potential L-1) and earlier potential L-3 (now potential L-2) values etc.

Qualification criteria will be applied to the individual contracts with combined evaluation methodology. If L1 bidder is not qualifying due to lack of bid capacity in remaining bids, then L2 may be considered if the variation between L1 and L2 is within a reasonable 5 % and bid amount is acceptable by the authority.

{Not Applicable in case of one package/contract, Delete Cl. 4.5D}

E. If the bidder is a Joint Venture, the partners would be limited to three (including lead partner). Joint Venture firms shall be jointly and severally responsible for completion of the project. Joint Venture must fulfill the following minimum qualification requirement.

- i. Deleted.
- ii. Deleted.
- iii. The Joint Venture must also collectively satisfy the subject of the criteria of Clause 4.5 B(a), 4.4 B(b) and 4.5 D of ITB for this purpose the relevant figures for each of the partners shall be added together to arrive at the Joint Venture total capacity which shall be 100% or more.
- iv. In the event that the Employer has caused to disqualify under Clause 4.8 of ITB below all of the Joint Venture partners will be disqualified.
- v. Joint Venture bidders shall provide a certified copy of the Joint Venture Agreement in demonstration of the partners undertaking joint and several liabilities for the performance of any contract entered into before award of work.
- vi. The available bid capacity of the JV as required under Clause 4.7 of ITB below will be applied for each partner to the extent of his proposed participation in the execution of the work. The total bid capacity available shall be more than estimated contract value.

Note: i) The joint venture partners should collectively meet the required responsiveness, technical and financial qualifications as stated in Clause 4.5A(a), 4.5A(b) and 4.5B (c) but the minimum equity of lead partner should not be less than 50% and others partner should not be less than 25%.

ii) Qualification of a joint venture does not necessarily qualify any of its

partners individually or as a partner in any other joint venture. In case of dissolution of a joint venture, each one of the constituent firms may qualify if they meet all the qualification requirements, subject to the written approval of the Employer.

4.6. Sub contractor's experiences and resources shall not be taken in to account in determining the bidder's compliance with the qualifying criteria.

4.7. Bidders who meet the minimum qualifying criteria will be qualified only if their available bid capacity at the expected time of bidding is more than the total estimated cost of the works. The available bid capacity will be calculated as under.

Assessed Available Bid Capacity = $(A*N*2.0-B)$, where

A = Maximum value of works executed in any one year during the last five years (updated to the current price level) rate of inflation may be taken as 10 percent per year which will take into account the completed as well as works in progress.

B = Value at current price level of the existing commitments and ongoing works to be completed during the next year (period of completion of works for which bids are invited). And

N = Number of years prescribed for completion of the works for which the bids are invited. (period up to 6 months to be taken as $\frac{1}{2}$ and more than 6 months as 1 in a year)

Note: 1- In case of a joint venture, the available bid capacity will be applied for each partner to the extent of his proposed participation in the execution of the works.

2- The statements showing the value of existing commitments and on-going works as well as the stipulated period of completion remaining for each of the works listed should be countersigned by the Engineer in charge, not below the rank of an Executive Engineer or equivalent.

4.8. Disqualification.

Even though the bidders meet the above criteria, they are subject to be disqualified if they have:

4.8.1 made misleading or false representations in the form, statements submitted; and/or

4.8.2 record of poor performance such as abandoning the works, rescinding of contract for which the reasons are attributable to the non-performance of the contractor, consistent history of litigation awarded against the bidder or financial failure due to bankruptcy. The rescinding of contract of a joint venture on account of reasons other than the non-performance, such as Most Experienced partner of joint venture pulling out, court directions leading to breaking up of a joint venture before the start of work, which are not attributable to the poor performance of the contractor will, however, not affect the qualification of the individual partners.

4.9. Litigation History:

The bidder should provide accurate information on any litigation or arbitration resulting from contracts completed or under execution by him over the last five years.

A consistent history of litigation against the bidder or any partner of a joint venture may result in failure of the bidder.

4.10. Deleted

5. One Bid per Bidder

5.1. Each bidder shall submit only one bid for one package. A bidder who submits or participates in more than one Bid (other than as a subcontractor or in cases of alternatives that have been permitted or requested) will cause all the proposals with the Bidder's participation to be disqualified.

6. Cost of Bidding

6.1. The bidder shall bear all costs associated with the preparation and submission of his Bid, and the Employer will in no case be responsible and liable for those costs.

7. Site Visit

7.1. The Bidder, at the Bidder's own responsibility and risk is encouraged to visit and examine the Site of Works and its surroundings and obtain all information that may be necessary for preparing the Bid and entering into a contract for construction of the Works. The costs of visiting the Site shall be at the Bidder's own expense.

B. BIDDING DOCUMENTS

8. Content of Bidding Documents

8.1. The set of bidding documents comprises the documents listed below and addenda issued in accordance with Clause 10:

Section	Particulars	Volume No.
	Invitation for Bids	I
1	Instructions to Bidders	
2	Qualification Information and other forms	
3	Conditions of Contract	
4	Contract Data	
5	Scope of Work & Technical Specifications	II
6	Form of bid	III
7	Bill of Quantities	
8	Securities and other forms	
9	Drawings	IV
10	Documents to be furnished by bidder	V

8.2. The bid document is available online on the website <http://etender.up.nic.in>. The bid document can be downloaded free of cost; however, the Bidder is required to deposit towards the cost of Bid Document (*non-refundable*) as per column no. 11 of IFB in the account of as mentioned in Appendix to ITB.

8.3. The bidder is expected to examine carefully all instructions, conditions of contract, contract data, forms, terms, technical specifications, bill of quantities, forms, Annexures, and drawings in the Bid Document. Failure to comply with the requirements of Bid Documents shall be at the bidder's own risk. Pursuant to clause 26 hereof, bids which are not substantially responsive to the requirements of the Bid Documents shall be rejected.

9. Clarification of Bidding Documents

9.1 A prospective Bidder requiring any clarification of the bidding documents may send his queries to Employer on email urida.goup@gmail.com & chiefengineernagarnigam@gmail.com prior to Pre Bid meeting. The Authority inviting bid will respond to any request (s) for clarification received earlier than 10 days prior to the deadline for submission of bids. Description of clarification sought and the response of the Authority inviting the bid will be uploaded for information of the public or other bidders without identifying the source of request for clarification.

- 9.2 Pre-bid meeting date, time and address are given in the Appendix to ITB.
- 9.3 The purpose of the meeting will be to clarify issues and to answer questions on any matter that may be raised at that stage.
- 9.4 Minutes of the meeting, including the text of the questions raised (without identifying the source of the enquiry) and the responses given will be uploaded for information of the public or other bidders. Any modifications of the bidding documents listed in Clause 8.1 of ITB, which may become necessary as a result of the pre-bid meeting shall be made by the Employer exclusively through the issue of an Addendum pursuant to Clause 10 of ITB and not through the minutes of the pre-bid meeting.
- 9.5 Non-attendance at the pre-bid meeting will not be a cause for disqualification of a bidder.

10. Amendment of Bidding Documents

- 10.1. Before the deadline for submission of bids, the Employer may modify the bidding documents by issuing addenda.
- 10.2. Any addendum thus issued shall be part of the bidding documents and shall be uploaded in <http://etender.up.nic.in>
- 10.3. To give prospective bidders reasonable time in which to take an addendum into account in preparing their bids, the Employer may, at his discretion, extend as necessary the deadline for submission of bids, in accordance with Sub-Clause 20.2 below.

C. PREPARATION OF BIDS

11. Language of the Bid

- 11.1. All documents relating to the bid shall be in the English language.

12. Documents Comprising the Bid

- 12.1. The bid to be submitted by the bidder as Volume V of the bid document (refer 1) shall be in two separate parts:

Part I shall be named "Technical Bid" and shall comprise

- i. Bid Security in the form specified in Section 8
- ii. Cost of Bid Document specified in Cl. 8.2, IFB column 11.
- iii. Qualification Information and supporting documents as specified in Section 2

- iv. Certificates, undertakings, affidavits as specified in Section 2.
- v. Undertaking that the bid shall remain valid for the period specified in Clause 15.1

Part II shall be named " Financial Bid" and shall comprise

- i. Form of Bid as specified in Section 6
- ii. Priced Bill of Quantities for items specified in Section 7[1]

12.2. Deleted.

12.3. Following documents, which are not submitted with the bid, will be deemed to be part of the bid.

Section	Particulars	Volume No.
	Invitation for Bids (IFB)	
1	Instructions to Bidders	Volume I
3	Conditions of Contract	
4	Contract Data	
5	Scope of Work & Technical Specifications	Volume II
9	Drawings	Volume IV

13. Bid Prices

- 13.1. The contract shall be for the whole works as described in Sub-Clause 1.1, based on the priced Bill of Quantities submitted by the Bidder online.
- 13.2. The bidder shall fill in quote the rates in percentage below/ at par/above of the rates described in the Bill of Quantities as available online.
- 13.3. All duties, taxes, and other levies payable by the contractor under the contract, or for any other cause shall be included in the rates, prices and total Bid Price submitted by the Bidder.
- 13.4. The rates quoted by the bidder shall be fixed for the duration of the Contract and shall not be subject to adjustment on any account.

14. Currencies of Bid and Payment

- 14.1. All payments shall be made in Indian Rupees.

15. Bid Validity

- 15.1. Bids shall remain valid for a period not less than **120 days** after the deadline date for bid submission specified in Clause 20. A bid valid for a shorter period shall be rejected by the Employer as non-responsive. In case of discrepancy in bid validity period between that given in the undertaking pursuant to Clause 12.1 (v) and the Form of Bid submitted by the bidder, the latter shall be deemed to stand corrected in accordance with the former and the bidder has to provide for any additional security that is required.
- 15.2. In exceptional circumstances, prior to expiry of the original time limit, the Employer may request that the bidders may extend the period of validity for a specified additional period. The request and the bidders' responses shall be made in writing. A bidder may refuse the request without forfeiting his bid security. A bidder agreeing to the request will not be required or permitted to modify his bid except as provided in 15.3 hereinafter, but will be required to extend the validity of his bid security for a period of the extension, and in compliance with Clause 16 in all respects.
- 15.3. Deleted
- 15.4. Deleted

16. Bid Security/Earnest Money Deposit (EMD)

- The Bidder shall pay bid security/EMD online as the amount mentioned in column no. 9 of the table of IFB for this particular work.
- The Bid Security shall be deposited in the Govt. Account as stated in the Appendix to ITB.
- Any bid not accompanied by an acceptable Bid Security and not secured as indicated in Sub-Clauses 16.1 and 16.2 above shall be rejected by the Employer as non-responsive.
- The Bid Security of unsuccessful bidders will be returned within 28 days of the end of the bid validity period specified in Sub-Clause 15.1 or 15.2 as the case may be.
- The Bid Security of the successful bidder will be discharged when the bidder has signed the Agreement and furnished the required Performance Security.
- The Bid Security may be forfeited
 - a. If the Bidder withdraws the Bid after Bid opening during the period of Bid validity;

- b. If the Bidder does not accept the correction of the Bid Price, pursuant to Clause 27;
or
- c. In the case of a successful Bidder, if the Bidder fails within the specified time limit to
 - (i) sign the Agreement; or
 - (ii) furnish the required Performance Security.

17. Alternative Proposals by Bidders

17.1. Bidders shall submit offers that fully comply with the requirements of the bidding documents, including the conditions of contract (including mobilization advance or time for completion), basic technical design as indicated in the drawing and specifications. Conditional offer or alternative offers will not be considered further in the process of tender evaluation.

18. Format and Signing of Bid

- 18.1. The Bidder shall submit online one set of bid documents comprising of the documents as described in Cl.12 of the Instructions to Bidders.
- 18.2. The Bid shall be signed by a person or persons duly authorized to sign on behalf of the Bidder, pursuant to Sub-Clauses 4.3. All pages of the bid where entries or amendments have been made shall be initialed by the person or persons signing the bid.
- 18.3. The Bid shall contain no alterations or additions, except those to comply with instructions issued by the Employer, or as necessary to correct errors made by the bidder, in which case such corrections shall be initiated by the person or persons signing the bid.

D. SUBMISSION OF BIDS

19. Electronic Submission of Bids

19.1. The Bidder shall submit two separate digitally signed files marked as "Technical Bid (Cover-1)" and "Financial Bid (Cover-2)". The contents of Technical and Financial Bids will be as specified in clause 12.1. All documents are to be signed digitally by the bidders.

- 19.2. Deleted.
- 19.3. Deleted.
- 19.4. Deleted.
- 19.5. The bidding under this contract is electronic bid submission through website <http://etender.up.nic.in> . Detailed guidelines for viewing bids and submission of online bids are given on the website. The prospective bidder can submit bids online; however, the bidder is required to have enrolment/registration in the website and should have a valid Digital Signature Certificate (DSC) in the form of smart card/e- token. The DSC can be obtained from any authorized certifying agencies. The bidder should register in the <http://etender.up.nic.in> using the relevant option available. Then the Digital Signature registration has to be done with the e-token, after logging into the site. After this, the bidder can login the site through the secured login by entering the password of the e-token and the user id/ password chosen during registration.

20. Deadline for Submission of the Bids

- 20.1. Complete bids (including Technical and Financial Bids) must be uploaded online through e-portal before the date and time (as per server clock) as specified in the Appendix to ITB. The Employer will assume no responsibility for delay caused due to non-availability of internet connection or network traffic jam etc.
- 20.2. The Employer may extend the deadline for submission of bids by issuing an amendment in accordance with Clause 10, in which case all rights and obligations of the Employer and the bidders previously subject to the original deadline will then be subject to the new deadline.

21. Late Bids

Late bids are not accepted.

22. Modification and Withdrawal of Bids

- 22.1. The electronic bidding system would not allow any late submission of bids after due date and time as per server time.
- 22.2. Each Bidder's modification or withdrawal notice shall be prepared and uploaded online in accordance with clause 20 or pursuant to clause 19.
- 22.3. No bid shall be modified or withdrawn after the deadline of submission of bids.

- 22.4. Neither withdrawal nor modification of a Bid is allowed between the deadline for submission of bids and the expiration of the original period of bid validity specified in Clause 15.1 above or as extended pursuant to Clause 15.2.

E. BID OPENING AND EVALUATION

23. Bid Opening

- 23.1. The Employer will open all the Bids received including modifications made pursuant to Clause 22, in the presence of the Bidders or their representatives who choose to attend at the time, date and the place specified in the Appendix to ITB in the manner specified in Clause 20, 23.3, online also. In the event of the specified date of Bid opening being declared a holiday for the, the Bids will be opened at the appointed time and location on the next working day by **Evaluation Committee**.
- 23.2. Deleted.
- 23.3. The "Technical Bid" shall be opened at the stipulated date and time.
- 23.4. (i) Subject to confirmation of the bid security by the issuing Bank, the bids accompanied with valid bid security will be taken up for evaluation with respect to qualification information as per Section 1.
- (ii) During evaluation if required, the bidder will be asked in writing to clarify his technical bid, if necessary.
- (iii) The bidders will respond in not more than 3 days (by email only) of issue of the clarification letter, which will also indicate the date, time and venue of opening of the Financial Bid (usually on the 21st day of opening of the Technical Bid)
- (iv) Immediately (usually within 3 or 4 days), on receipt of these clarifications the Evaluation Committee will finalize the list of responsive bidders whose financial bids are eligible for consideration.
- 23.5. Deleted.
- 23.6. At the time of opening of "Financial Bid", the names of the bidders found responsive in accordance with Clause 23.4(iv) will be announced. The bids of only these bidders will be opened. The remaining bids will be returned to the bidders unopened. The responsive Bidders' names, the Bid prices, the total amount of each bid, any discounts, Bid Modifications and withdrawals, and such other details as the Employer may consider appropriate, will be announced by the Employer at the opening. Any Bid price

or discount, which is not read out and recorded will not be taken into account in Bid Evaluation.

23.7. Deleted.

23.8. The Employer shall prepare minutes of the Bid opening, including the information disclosed to those present in accordance with Sub-Clause 23.5.

24. Process to be Confidential

24.1. Information relating to the examination, clarification, evaluation, and comparison of Bids and recommendations for the award of a contract shall not be disclosed to Bidders or any other persons not officially concerned with such process until the award to the successful Bidder has been announced. Any effort by a Bidder to influence the Employer's processing of Bids or award decisions may result in the rejection of his Bid.

25. Clarification of Financial Bids

25.1. To assist in the examination, evaluation, and comparison of Bids, the Employer may, at his discretion, ask any Bidder for clarification of his Bid. The request for clarification and the response shall be in writing, but no change in the price or substance of the Bid shall be sought, offered, or permitted.

25.2. Deleted.

25.3. Any effort by the Bidder to influence the Employer in the Employer's bid evaluation, bid comparison or contract award decisions, may result in rejection of the Bidders' bid.

26. Examination of Bids and Determination of Responsiveness

26.1. During the detailed evaluation of "Technical Bids", the Evaluation Committee will determine whether each Bid (a) meets the eligibility criteria defined in Clause 3 and 4; (b) has been properly signed; (c) is accompanied by the required securities and; (d) is substantially responsive to the requirements of the Bidding documents. During the detailed evaluation of the "Financial Bid", the responsiveness of the bids will be further determined with respect to the remaining bid conditions, i.e., priced bill of quantities, technical specifications, and drawings.

26.2. A substantially responsive "Financial Bid" is one which conforms to all the terms, conditions, and specifications of the Bidding documents, without material deviation or reservation. A material deviation or reservation is one (a) which affects in any substantial way the scope, quality, or performance of the Works; (b) which limits in any substantial way, inconsistent with the Bidding documents, the Employer's rights or the

Bidder's obligations under the Contract; or (c) whose rectification would affect unfairly the competitive position of other Bidders presenting substantially responsive Bids.

26.3. If a "Financial Bid" is not substantially responsive, same will be rejected by the Employer, and may not subsequently be made responsive by correction or withdrawal of the non-conforming deviation or reservation.

27. Deleted.

28. Deleted.

29. Evaluation and Comparison of Financial Bids

29.1. The Employer will evaluate and compare only the Bids determined to be substantially responsive in accordance with Sub-Clause 26.2.

29.2. In evaluating the Bids, the Employer will determine for each Bid the evaluated Bid Price by adjusting the Bid Price as follows:

- a. Deleted.
- b. making an appropriate adjustment for any other acceptable variations, deviations; and
- c. making appropriate adjustments to reflect discounts or other price modifications offered in accordance with Sub-Clause 23.6.

29.3. The Employer reserves the right to accept or reject any variation or deviation. Variations and deviations and other factors, which are in excess of the requirements of the Bidding documents or otherwise result in unsolicited benefits for the Employer shall not be taken into account in Bid evaluation.

29.4. The estimated effect of the price adjustment conditions under Clause 47 of the *Conditions of Contract*, during the period of implementation of the Contract, will not be taken into account in Bid evaluation.

29.5. If the Bid of the successful Bidder is seriously unbalanced i.e. (+/-) 15% in relation to the Engineer's estimate of the cost of work to be performed under the contract, the Employer may require the Bidder to produce detailed price analyses for any or all items of the Bill of Quantities, to demonstrate the internal consistency of those prices with the construction methods and schedule proposed. After evaluation of the price analysis, the Employer may require that the amount of the performance security set forth in Clause 34 & conditions for NIT be increased at the expense of the successful Bidder to a level sufficient to protect the Employer against financial loss in the event of default of the successful Bidder under the Contract.

29.6. Deleted.

30. Deleted

F. AWARD OF CONTRACT

31. Award Criteria

31.1. Subject to Clause 32, the Employer/Authority will award the Contract to the Bidder whose Bid has been determined

- (i) to be substantially responsive to the Bidding documents and who has offered the lowest evaluated Bid Price; and
- (ii) to be within the available bid capacity adjusted to account for his bid price which is evaluated the lowest in any of the packages opened earlier than the one under consideration.

In no case, the contract shall be awarded to any bidder whose available bid capacity is less than the evaluated bid price, even if the said bid is the lowest evaluated bid. The contract will in such cases be awarded to the next lowest bidder at his evaluated/negotiated bid price.

32. Employer's Right to Accept any Bid and to Reject any or all Bids

32.1. Notwithstanding Clause 31, the Employer reserves the right to accept or reject any Bid, and to cancel the Bidding process and reject all Bids, at any time prior to the award of Contract, without thereby incurring any liability to the affected Bidder or Bidders or any obligation to inform the affected Bidder or Bidders of the grounds for the Employer's action.

33. Notification of Award and Signing of Agreement

33.1. The Bidder whose Bid has been accepted will be notified of the award by the Employer prior to expiration of the Bid validity period by mail chiefengineernagarnigam@gmail.com confirmed by registered letter. This letter (hereinafter and in the *Conditions of Contract* called the "**Letter of Acceptance**") will state the sum that the Employer will pay the Contractor in consideration of the execution, completion, and maintenance of the Works by the Contractor as prescribed by the Contract (hereinafter and in the Contract called the "**Contract Price**").

33.2. The notification of award will constitute the formation of the Contract, subjected to the furnishing of a performance security in accordance with provisions of Clause 31.

33.3. The Agreement will incorporate all agreements between the Employer and the successful Bidder. It will be signed by the Employer and sent to the successful Bidder, within 28 days following the notification of award along with the Letter of Acceptance. Within 21 days of receipt, the successful Bidder will sign the Agreement and deliver it to the Employer.

33.4. Upon the furnishing by the successful Bidder of the Performance Security, the Employer will promptly notify the other Bidders that their Bids have been unsuccessful.

34. Performance Security

34.1. Within 21 days of receipt of the Letter of Acceptance, the successful Bidder shall deliver to the Employer a **Performance Security** in any of the forms given below for an amount equivalent to 5% of the Contract price plus additional security for unbalanced Bids in accordance with Clause 29.5 of ITB and Clause 52 of Conditions of Contract:

- A bank guarantee in the form given in Section 8; or
- Certified Cheque / Bank Draft as indicated in Appendix to ITB.

34.2. If the performance security is provided by the successful Bidder in the form of a Bank Guarantee, it shall be issued either (a) at the Bidder's option, by a Nationalized/ Scheduled Indian bank or (b) by a foreign bank located in India and acceptable to the Employer.

34.3. Failure of the successful Bidder to comply with the requirements of Sub-Clause 34.1 shall constitute sufficient grounds for cancellation of the award and forfeiture of the Bid Security.

35. Advance Payment and Security

35.1. The Employer may provide an Advance Payment on the Contract Price as stipulated in the Conditions of Contract, subject to maximum amount, as stated in the Contract Data.

36. Dispute Review Expert

36.1. In case of any dispute the official appointed by URIDA/Employer shall take the final decision and it should be binding.

37. Corrupt or Fraudulent Practices

37.1. The Employer will reject a proposal for award if it determines that the Bidder recommended for award has engaged in corrupt or fraudulent practices in competing for the contract in question or, to be awarded a contract with National Highways Authority of India / State PWD and any other agencies or in execution will declare the firm ineligible, either indefinitely or for a stated period of time,

37.2. Furthermore, Bidders shall be aware of the provision stated in Sub-Clause 23.2 and Sub-Clause 59.2 of the Conditions of Contract (Section-3).

{Kindly fill the amount in Lacs only}

Appendix to ITB
Clause Reference with respect to Section-I

1.	Name of the Employer/Tender Inviting Authority [Cl. 1.1]	Municipal Commissioner, Kanpur Municipal Corporation.
2.	The last five years:	Financial Year 2019- 2020, 2020-2021, 2021-2022, 2022-2023 and 2023-2024
	The annual financial turnover amount. [Cl. 4.5A(a)]	INR [Fill in numbers & words] or above
3.	Value of work [Cl. 4.5A(b)]	INR [Fill in numbers & words] or above
4.	Quantities of work [Cl. 4.5A(c)]	INR [Fill in numbers & words] or above
5.	Cost of electric work (Street lightning and underground electrification)	INR [Fill in numbers & words] or above
6.	Liquid assets and/or availability of credit facilities [Cl. 4.5B(c)]	INR [Fill in numbers & words] or above
7.	Price level of the financial year [Cl. 4.7]	10%
8.	Date and Place of Prebid [Cl. 9.2]	12:07:2024 ,3:00 PM URIDA HEADQUARTERS (3rd Floor, Directorate of Urban Local Bodies, sector 7, Gomti Nagar, Lucknow, Uttar Pradesh)
9.	Last date and time for receipt of proposal [Cl. 20.1]	06/08/24, 03:00 pm
10.	Date and time of opening of technical proposal [Cl. 23]	06/08/2024 04:00 pm Office of Chief Engineer , Kanpur Municipal Corporation.
11.	Date and time of opening of financial bids	To be communicated through email
12.	Duration of contract	Completion time + 5 years
13.	Method of Selection	Least Cost Selection (LCS)
14.	Address of the Authority [Cl. 4.5(a)]	Motijheel , Kanpur
15.	Identification	133/CE/24-25, Baba Kuti intersection to Alankar Guest House (Length 2.34 km) via Sote Baba Mandir is being carried out, Under Zone -03
16.	The bid will be opened at (office address) [Cl. 23.1]	Office of Chief Engineer , Kanpur Municipal Corporation

17.	The Bank Draft in favor of [Cl 34.1]	Chief Account Officer , Kanpur Nagar Nigam
18.	Cost of Bid Document (Tender Fee): - To be deposited in the account of [Cl. 8.2]	Name- Kanpur Nagar Nigam A/C- 91602005942390 IFSC code : UTI 000133 Bank - Axis Bank Branch - R.K Nagar
19.	Bid Security: Bidder has to Pay the EMD/Bid Security in the Govt. Account [Cl. 16.2]	Name- Kanpur Nagar Nigam A/C- 91602005942390 IFSC code : UTI 000133 Bank - Axis Bank Branch - R.K Nagar
20.	Performance Bank Guarantee	5% of the contract value

ANNEXURE-I

List of Key Plant & Equipment to be deployed on Contract Work
(update/modify the list of equipments as per requirement of ULB)

[Reference Cl. 4.5 (B) (a)]

Sl. No.	Type of Equipment	Maximum age in Years as on 30-06-2024 (Update as per requirement)	Contract Package Size	
			Upto Rs. 25 Cr.	Greater than 25 Cr.
A]	Key Plant & Equipment	5		
1.	Dozer	5		●
2.	Excavator (1 cum bucket capacity)	5		●
3.	Backhoe Loader cum Excavator (JCB)	5		●
4.	Front end Loader	5		●
5.	Motor Grader	5		●
6.	Vibratory Roller (10 to 13 T)	5		●
8.	Tippers (5.50 cum / 10 MT capacity)	5		●
10.	Water Tanker	5		●
11.	Wet Mix Macadam Plant	5		●
12.	Paver Finisher for WMM/DLC	5		●
14.	Hot Mix Plant with Electronic Controls (Minimum 80-100 TPH capacity)	5		●
15.	Paver Finisher with Electronic Sensor for DBM & BC	5		●
16.	Tar Boiler	5		●
17.	Bitumen Sprayer	5		●
18.	Smooth Wheeled Tandem roller (6 to 8 T)	5		●
19.	Pneumatic tired roller (10 to 14 Ton)	5		●
20.	Tractor with trolley	5		●
21.	Air compressor	5		●
22.	Mechanical Broom	5		●
23.	Concrete Mixes with Integral Weigh Batching facility	5		●
24.	Fixed form paver	5		●
25.	Self-loading concrete mixer / Fiori or equivalent	5		●
26.	Surface Vibrator	5		●
27.	Needle/Pin Vibrator	5		●
28.	Rotavator (as per requirement)	5		●
29.	Concrete joint cutting machine for CC Pavement	5		●
30.	Palfinger access platform or similar (for electrical works)	5		●
31.	Total Survey Station and Auto Levels	5		●

B]	Testing apparatus	5		●
1.	Riffle Box	5		●
2.	Sieve Set for GSB, DLC, WBM	5		●
3.	Sieve Shaker 450 mm	5		●
4.	Speedy moisture meter with Chemical	5		●
5.	Atterberg Limits Apparatus	5		●
4.	Compression Machine	5		●
5.	Moisture Tins	5		●
6.	Spatula	5		●
7.	Aggregate Impact value Test Machine	5		●
8.	Flakiness & Elongation Testing gauge	5		●
9.	3 Meter Straight Edge with wedges	5		●
10.	Water Bath	5		●
11.	Penetration Machine	5		●
12.	Softening point Test machine	5		●
13.	Bitumen Extraction Machine	5		●
14.	Sand Replacement Method Earth embankment	5		●
15.	Core Cutter for Embankment density	5		●
16.	Core cutting Machine for BC & DBM (Wax method)	5		●
17.	Primer Coat & Tack coat testing Plates	5		●
18.	Cube Mould (15x15x15) Cm	5		●
19.	Slump Test Machine	5		●
20.	Cement Testing Kit	5		●
21.	Penetration Machine with Accessory	5		●
22.	softening point Apparatus with Accessory	5		●
23.	Viscosity (Say bolt Fulrol) with Accessories	5		●
24.	Ductility Machine with Accessories	5		●

Note: Apart from above mentioned list, additional plant & machinery may be mobilized as per the project requirement/specific work, which is not mentioned herein.

ANNEXURE-II
List of Key Personnel to be deployed on Contract Work
Update/modify the required personnel as per ULB requirement

[Reference Cl. 4.5 (B) (b)]

For Civil & Electrification Works.

SI.NO	Personnel	Qualification	Contract Package Size	
			C	D
	A	B	Upto Rs. 25 Crores	Greater than 25 crores
1.	Project Manager	B.E. Civil + 15 Years Exp. (5 years as in Integrated road projects)	1 Nos.	2 Nos.
2.	Site Engineer	B.E. Civil + 5 Years Exp. or Diploma Civil + 10 years' Experience (5 years in Road Construction)	1 Nos.	2 Nos.
3.	Architect/ Urban Designer	B.Arch./Bachelor in Urban Designer +7 years or Masters in Urban Design or equivalent + 5 years (5 years in Urban landscaping work)	1 Nos.	2 Nos.
4.	Quantity Surveyor	B.E. Civil + 7 years Exp. or Dip. Civil + 10 years Exp.	2 Nos.	3 Nos.
5.	Soil & Material Engineer	B.E. Civil + 10 years Exp.	1 Nos.	2 Nos.
6.	Surveyor	Dip. Civil + 5 years Exp.(Also experience in the Power sector)	1 Nos.	2 Nos.
7.	Lab Technician	5 years Exp. or Dip. Civil	2 Nos.	3 Nos.
8.	Electrical Engineer	B.E Electrical Engineering + 7 years or Diploma Electrical +10 years (Safety License)	1 Nos.	2 Nos.
9.	Technician (Electrical)	ITI/Diploma in Electrical Engineering + 5 years' experience	1 Nos.	2 Nos.
	Total			

For Routine Maintenance

SI. No.	Personnel	Qualification	Contract Package	
			Upto Rs. 25 Crores	Greater than 25 crores
	A	B	C	D
1	Site-In-charge	Degree Holder in Civil Engineering+ 2 years' experience	1 No.	2 Nos.
2	Assistant Site-In-charge	Diploma Holder in Civil Engineering +2 years' experience	1 No.	2 Nos.

ANNEXURE III

Provisions required to be Included in the Joint Venture Agreement

If the application is made by a joint venture of two or more firms, the evidence of clear mandate (i.e. in the form of respective Board Resolution duly authenticated by competent authority*) by such two or more firms willing to form Joint Venture among themselves for the specified projects should accompany duly recognizing their respective authorized signatories signing for and on behalf of the respective Firms for the purpose of forming the Joint Venture. A certified copy of the power of attorney to the authorized representatives, signed by legally authorized signatories of all the firms of the joint venture shall accompany the application. The JV Agreement shall be signed by the authorized representative of the joint venture. The JV Agreement shall need to be submitted consisting but not limited to the following provisions:

- a) Name, style and Project(s) specific JV with Head Office address.
- b) Extent (or Equity) of participation of each party in the JV.
- c) Commitment of each party to furnish the Bond money (i.e. Bid Security, performance Security and security for Mobilization advance) to the extent of his participation in the JV
- d) Responsibility of each Partner of JV (in terms of Physical and Financial involvement).
- e) Working Capital arrangement of JV.
- f) Operation of separate Bank account in the name of JV to be operated by at least one foreign partner and one local partner. In case of JV among local partners, both the partners are required to operate.
- g) Provision for cure in case of non-performance of responsibility by any party of the JV.
- h) Provision that NEITHER party of the JV shall be allowed to sign, pledge, sell or otherwise dispose all or part of its respective interests in JV to any party including existing partner(s) of the JV The Employer derives right for any consequent action (including blacklisting) against any or all JV partners in case of any breach in this regard.
- i) Management Structure of JV with details.
- j) Lead Partner to be identified who shall be empowered by the JV to incur liabilities on behalf of JV.
- k) Parties/firms committing themselves to the Employer for jointly and severally responsible for the intended works.
- l) The Power of Attorney shall be duly notarized.
- m) Any other relevant details.

THIS PAGE HAS BEEN INTENTIONALLY KEPT BLANK

SECTION 2: - QUALIFICATION INFORMATION

QUALIFICATION INFORMATION

The information to be filled in by the Bidder in the following pages will be used for purposes of post qualification as provided for in Clause 4 of the Instructions to Bidders. This information will not be incorporated in the Contract.

1. For Individual Bidders

1.1. Constitution or legal status of Bidder

[Attach copy]

Place of registration:

Principal place of business:

Power of attorney of signatory of Bid

[Attach]

1.2	Total annual volume of civil engineering construction work executed and payments received in the last five years** preceding the year in which bids are invited. (Attach certificate from Chartered Accountant)	(Rs. In lakhs) FY 2019-20- _____ FY 2020-21- _____ FY 2021-22- _____ FY 2022-23- _____ FY 2023-24 - _____	β
-----	---	---	----------

1.3 Work performed as prime contractor, work performed in the past as a nominated sub contractor will also be considered provided the sub-contract involved execution of all main items of work described in the bid document, provided further that all other qualification criteria are satisfied (in the same name) on works of a similar nature over the last five years. **

Project Name	Name of the Employer*	Description of work	Contract No.	Value of Contract (Rs crore)	Date of issue of work order	Stipulated period of completion	Actual date of completion *	Remarks explaining reasons for delay & work Completed

* Attach certificate(s) from the Engineer(s)-in-Charge

** immediately preceding the financial year in which bids are received.

β Attach certificate from Chartered Accountant.

1.3.2

1.4. Information on Bid Capacity (works for which bids have been submitted and works which are yet to be completed) as on the date of this bid.

(A) Existing commitments and on-going works:

Description of works	Place & State	Contract No.	Name & Address of Employer	Value of Contract (Rs Cr)	Stipulated Period of Completion	Value of works* remaining to be completed {Rs Cr}	Anticipated date of completion
1	2	3	4	5	6	7	8

--	--	--	--	--	--	--	--

**Attach certificate(s) from the Engineers)-in-Charge*

@The item of work for which data is requested should tally with that specified in ITB clause 4.5A(c).

*** immediately preceding the financial year in which bids are received.*

(B) Works for which bids already submitted:

Description of works	Place & Slate	Name & Address of Employer	Estimated value of works (Rs Cr)	Stipulated period of completion	Date when decision is expected	Remarks, if any
1	2	3	4	6	6	7

1.5. Availability of key items of Contractor's Equipment essential for carrying out the Works [Ref. Clause 4.5(B)(a)]. The Bidder should list all the information requested below. Refer also to Sub Clause 4.3 (d) of the Instructions to Bidders.

Item of Equipment	Requirement		Availability proposals			Remarks (from whom to be purchased)
	No.	Capacity	Owned/Leased to be procured	Nos/Capacity	Age/Condition	

1.6. Qualifications and experience of key personnel required for administration and execution of the Contract [Ref. Clause 4.5(B)(b)]. Attach biographical data. Refer also to Sub Clause 4.3 (e) of instructions to Bidders and Sub Clause 9.1 of the Conditions of Contract.

Position	Name	Qualification	Year of Experience (General)	Years of experience in the proposed position
Project Manager				
Etc.				

1.7. Proposed sub-contracts and firms involved. [Refer ITB Clause 4.3 (k)]

Sanctions of the works	Value of Sub-contract	Sub-contractor (Name & Address)	Experience in similar work

Attach copies of certificates on possession of valid license for executing water supply / sanitary work / electrification works [Reference Clause 4.5.A.(d) & Clause 4.5.A(e)]

- 1.8. Financial reports for the last five years: balance sheets, profit and loss statements, auditors' reports (in case of companies/corporation), ITR, etc. List them below and attach copies.
- 1.9. Evidence of access to financial resources to meet the qualification requirements: cash in hand, lines of credit, etc. List them below and attach copies of support documents.
- 1.10. Name, address, and telephone, and email of the Bidders' bankers who may provide references if contacted by the Employer.

1.11. Information on litigation history in which the Bidder is involved.

Other Party (ies)	Employer	Cause of Dispute	Amount involved	Remarks showing Present Status

1.12. Statement of compliance under the requirements of Sub Clause 3.2 of the instructions to Bidders. (Name of Consultant engaged for project preparation is _____)

1.13. Proposed work method and schedule. The Bidder should attach descriptions, drawings and charts as necessary to comply with the requirements of the Bidding documents. [Refer ITB Clause 4.1 & 4.3 (I)]

1.14. Programme [CI 4.3. (I)]

1.15. Quality Assurance Programme [CI 4.3. (I)]

2. **Deleted.**

3. Additional Requirements

3.1 Bidders should provide any additional information required to fulfill the requirements of Clause 4 of the Instructions to the Bidders, if applicable.

- (i) Affidavit shall be submitted on Rs 100.00 non-Judicial stamp paper duly notarized.
- (ii) Undertaking shall be submitted on Rs 100.00 non-Judicial stamp paper duly notarized

Balance Sheet & Statement of Profit & Loss for last five consecutive financial years ending **31.03.2024**

Financial Information in Rs. Equivalent	2019-20	2020-21	2021-22	2022-23	2023-24
1. Total Assets					
2. Current Assets					
3. Total Liabilities					
4. Current Liabilities					
5. Profit before Tax					
6. Profit after Tax					
7. Net Worth					
8. Bank solvency amount as mentioned in the bank solvency certificate (form "T- 1B")					

TECHNICAL EVALUATION

The following scoring criteria will be applicable for consideration of similar works.

Sl. No	Description	Marks
1	Carriageway works should include asphalt/ cement concrete surface with necessary base layers with minimum length equal to total length as mentioned in IFB column 5.	30
2	Footpath works include road works involving paver blocks/ kerbstone or concrete pathways and likewise with minimum length equal to total length as mentioned in IFB column 5.	10
3	Street lightning works with minimum length equal to total length as mentioned in IFB column 5.	10
4	Roadside landscapes works with minimum length equal to total length as mentioned in IFB column 5.	5
5	Underground utilities works, which includes gas, power, sewer, water supply, storm water and telecom works with minimum length equal to total length as mentioned in IFB column 5.	
	A) Power Line (LT/HT) (must be included in qualifying 80 marks)	15
	B) Storm water	10
	C) Sewer	05
	D) Water Supply	05
	E) Telecom (OFC)	05
	F) Gas	05
Total		100

- **Note:** If the work experience is of lesser length than mentioned as above, then the marks will be awarded on a pro-rata basis.
- The Bidder obtaining minimum 80 marks out of the above mentioned 100 marks will be qualified for this section provided Bidder must obtain 15 marks of power line (LT/HT) as mentioned in 5(A)

FORM T-1 B**FORM OF BANKERS' CERTIFICATE FROM A SCHEDULED BANK
(SOLVENCY CERTIFICATE)**

This is to certify that to the best of our knowledge and information that M/s./Shri having marginally noted address, a customer of our bank are/is respectable and can be treated as good for any engagement upto a limit of Rs.
(Rupees).

This certificate is issued without any guarantee or responsibility on the bank or any of the officers.

(Signature)

For the Bank

NOTE (1) Bankers certificates should be on letter head of the Bank, self-attested and should have been issued within Six months from original last date of submission of the Bid.

(2) In case of partnership firm, certificate should include names of all partners as recorded with the bank.

FORMAT FOR EVIDENCE OF ACCESS TO OR AVAILABILITY OF CREDIT FACILITIES

It shall be furnished by bank on their original letter head. The certificate should not be old by more than three months.

{Cl.4.3. g, Section 1}

BANK CERTIFICATE

This is to certify that M/s. _____ is a reputed company with a good financial standing.

If the contract for the work, namely.....is awarded to the above firm, we shall be able to provide overdraft/credit facilities to the extent of Rs. _____ to meet their working capital requirements for executing the above contract during the contract period.

(Signature)

Name of Bank

Senior Bank Manager

Address of the Bank

AFFIDAVIT
(Non-Blacklisting & Non- Rescind/abandon)

1. I, the undersigned, do hereby certify that all the statements made in the required attachments are true and correct.
2. The undersigned also hereby certifies that neither our firm i.e. _____ M/s _____ or our partners (in case of JV) have abandoned any work on any Government Organization nor any contract awarded to us for such works have been rescinded, during last five years prior to the date of this bid.
3. The undersigned hereby declare that we have not been debarred or placed on any **black list declared** by any Bank, Financial Institution and any Government Department.
4. The undersigned hereby authorize(s) and request(s) any bank, person, firm or corporation to furnish pertinent information deemed necessary and requested by the Department to verify this statement or regarding my (our) competence and general reputation.
5. The undersigned understand and agrees that further qualifying information may be requested, and agrees to furnish any such information at the request of the Department/ Project implementing agency.

(Signed by an Authorised Officer of the Firm)

Title of Officer

Name of Firm

Date

**UNDERTAKING
(Cash investment)**

{Cl. 4.3.h, Section 1}

I, the undersigned do hereby undertake that our firm M/s
would invest a minimum cash up to 25% of the value of the work during implementation of
the Contract.

(Signed by an Authorised Officer of the Firm)

Title of Officer

Name of Firm

Date

UNDERTAKING
(for Green Technologies)
{CI 4.4.A.b, Section I}

We have the experience of carrying out the works and we assure you that work shall be done as per specification

OR

Although we have not done work as specified but we assure that we will arrange human and material resource to carry out the work as per specification.

(Signed by an Authorised Officer of the Firm)

Title of Officer

Name of Firm

Date

FORM T-4**कार्यालय जिला मजिस्ट्रेट,**
चरित्र प्रमाण-पत्र

1. आवेदक का नाम श्री/श्रीमती.....
2. पिता/पति का नाम श्री.....
3. आयु.....
4. शैक्षिक योग्यता.....
5. व्यवसाय.....
6. पता- (अ) स्थाई पता दूरभाष सहित.....
.....
(ब) अस्थाई पता दूरभाष सहित.....
.....

राजपत्रित अधिकारी
द्वारा प्रमाणित
पासपोर्ट साइज का
नवीनतम फोटोग्राफ
चस्पा किया जाय

7. अपराधिक मुकदमों का विवरण.....

(व्यक्ति के विरुद्ध जनपद में दर्ज मुकदमों, अपराधिक गतिविधियों और असमाजिक कार्यों का विवरण दिया जाय। यदि किसी न्यायालय में अपराधिक मुकदमा चल रहा है तो उसका विवरण भी दिया जाय। यदि लोक निर्माण विभाग अथवा राज्य सरकार के अन्य निर्माण द्वारा ब्लैक लिस्टेड किया गया हो तो उसका विवरण भी दिया जाय। माफिया/गंगेस्टर गतिविधियों एवं संगठित अपराधों में लिप्त व्यक्तियों के बारे में विशेष रूप से जाँच करने के बाद ही प्रमाण पत्र निर्गत किया जाय और इसका उल्लेख इस कालम में अवश्य किया जाय।)

8. सामान्य ख्याति.....
9. प्रमाण-पत्र:-

मेरे द्वारा श्रीके कार्य और आचरण तथा चरित्र के संबंध में पूरी तथ्यात्मक जानकारी कर ली गई है। इनके विरुद्ध अपराधिक मुकदमों की सूचना भी पुलिस से प्राप्त की गई है। सभी तथ्यों की जानकारी के पश्चात् मैं प्रमाणित करता हूँ कि श्री..... का कार्य आचरण तथा चरित्र उत्तम है और इनके लोक निर्माण विभाग में अथवा राज्य सरकार के किसी विभाग में ठेकेदार का कार्य करने पर सामान्यतः आपत्ति प्रतीत नहीं होती है।
दिनांक.....

हस्ताक्षर
जिला मजिस्ट्रेट/कलेक्टर
(मुहर सहित)

नोट:-

1. जिला मजिस्ट्रेट/कलेक्टर द्वारा यह प्रमाण-पत्र अपने स्वयं के हस्ताक्षर से निर्गत किया जायेगा। उसके स्थान पर किसी अन्य अधिकारी द्वारा प्रमाण-पत्र निर्गत नहीं किया जायेगा।
2. प्रमाण-पत्र देने के पूर्व यह आवश्यकतानुसार वरिष्ठ पुलिस अधीक्षक/पुलिस अधीक्षक/तहसीलदार/एस. डी.एम./अपर जिलाधिकारी/अथवा किसी अन्य अधिकारी से जाँच कराकर रिपोर्ट प्राप्त कर सकते हैं।
3. संबंधित व्यक्ति से स्वघोषणा शपथ-पत्र भी ले सकते हैं।
4. यह प्रमाण पत्र सामान्यतः दो वर्ष के लिए मान्य होगा। यदि इससे पूर्व कोई अपराधिक घटना होती है अथवा प्रार्थी के विरुद्ध कोई अपराधिक मुकदमा आदि दर्ज होता है या यह किसी संगठित अपराध में या माफिया गतिविधियों में या असामाजिक गतिविधियों में पकड़ा जाता है तो पुलिस विभाग का यह उत्तरदायित्व होगा कि इसकी सूचना वह जिला मजिस्ट्रेट/कलेक्टर तथा संबंधित विभाग के अधिकारी को देगा और प्रमाण-पत्र तत्काल निरस्त किया जायेगा।
5. इस प्रमाण-पत्रों की प्रविष्टि जिलाधिकारी कार्यालय में तथा वरिष्ठ पुलिस अधीक्षक/पुलिस अधीक्षक कार्यालय में एक अलग रजिस्टर में विधिवत अंकित की जायेगी और निर्गत प्रमाण-पत्र की एक प्रमाणित फोटो प्रति रजिस्टर में अवश्य रखी जायेगी।

6. इस प्रमाण-पत्र के निर्गत करने अथवा निरस्त करने के संबंध में अंतिम निर्णय संबंधित जिला मजिस्ट्रेट/कलेक्टर का होगा।
7. निर्गत प्रमाण-पत्र की एक कार्यालय प्रति (Office copy) वरिष्ठ पुलिस अधीक्षक/पुलिस अधीक्षक कार्यालय में अवश्य रखी जायेगी और एक अलग रजिस्टर में प्रविष्टि अंकित की जायेगी। जिससे रिकार्ड रहे।
8. संबंधित व्यक्ति द्वारा पासपोर्ट साइज का अपना नवीनतम फोटोग्राफ, जो राजपत्रित अधिकारी द्वारा प्रमाणित हो, चरित्र प्रमाण-पत्र के ऊपर निर्धारित स्थान पर चस्पा किया जायेगा।

FORM T-5

कार्यालय जिला मजिस्ट्रेट.....

हैसियत प्रमाण-पत्र

1. प्रार्थी का नाम (व्यक्ति/फर्म/संस्था का नाम).....
2. पिता/पति का नाम.....
3. निवास स्थान
(अ) पूरा स्थायी पता दूरभाष सहित.....
.....
(ब) अस्ताई पता दूरभाष सहित.....
.....

राजपत्रित अधिकारी
द्वारा प्रमाणित
पासपोर्ट साइज का
नवीनतम फोटोग्राफ
चस्पा किया जाय

4. व्यवसाय.....
5. सम्पत्ति का विवरण:- जिला मजिस्ट्रेट/कलेक्टर के द्वारा चल/अचल सम्पत्ति/हैसियत के संबंध में पूरा विवरण निम्न प्रकार से दिया जाय।
i) अचल सम्पत्ति:- जमीन/भूखण्ड/मकान/दूकान/व्यवसायिक प्रतिष्ठान/उद्योग धन्धे आदि का विवरण। यह सम्पत्ति ठेकेदार के नाम है अथवा किसी अन्य व्यक्ति के नाम से है, इसका स्पष्ट उल्लेख किया जाय। इस संबंध में सक्षम अधिकारी द्वारा निर्गत प्रमाण-पत्र संलग्न किया जाय। सम्पत्ति का मूल्यांकन/बाजार मूल्य तथा सम्पत्ति बैंक अथवा किसी वित्तीय संस्था में मार्गेज हो तो उसका विवरण भी दिये जाय।
ii) चल सम्पत्ति:- मोटर वाहन/निर्माण कार्यो में प्रयुक्त मशीनों तथा अन्य चल सम्पत्ति का पूरा विवरण दिया जाय। यह सम्पत्ति ठेकेदार के नाम है अथवा किसी अन्य व्यक्ति के नाम से है, इसका स्पष्ट उल्लेख किया जाय। इस संबंध में सक्षम अधिकारी द्वारा निर्गत प्रमाण-पत्र संलग्न किया जाय। सम्पत्ति का मूल्यांकन/बाजार मूल्य कितना है। यह सम्पत्ति बैंक अथवा किसी वित्तीय संस्था में मार्गेज हो तो उसका विवरण भी दिये जाय।
6. बैंक अथवा वित्तीय संस्था में कोई धनराशि हो तो इसके लिए बैंक का नाम/खाता संख्या एवं उसमें रखी धनराशि का विवरण दिया जाय। इसके लिए बैंक अथवा वित्तीय संस्था द्वारा निर्गत प्रमाण पत्र संलग्न किया जाय।
7. हैसियत प्रमाण पत्र के लिए हैसियत के रूप में यदि बैंक में जमा धनराशि दर्शायी जाती है तो वह धनराशि कम से कम तीन माह से पहले बैंक में जमा होनी चाहिए और कार्य पूरा होने तक बैंक में अवश्य जमा रहनी चाहिए।
8. प्रार्थी का पैन नम्बर..... है।

मेरे द्वारा श्री (यहाँ व्यक्ति/फर्म/संस्था आदि का नाम लिखा जाय).....की चल और अचल सम्पत्ति के बारे में तथ्यों की जानकारी कर ली गई है और उसका विवरण उपरोक्तानुसार दिया गया है।

मैं प्रमाणित करता हूँ कि मेरी जानकारी में उपरोक्त सभी तथ्य सही हैं और तथ्यात्मक रिपोर्ट के आधार पर यह प्रमाण-पत्र निर्गत किया जा रहा है।

दिनांक.....

हस्ताक्षर

जिला मजिस्ट्रेट/कलेक्टर
(मुहर सहित)

नोट:-

1. जिला मजिस्ट्रेट/कलेक्टर द्वारा यह प्रमाण-पत्र अपने स्वयं के हस्ताक्षर से निर्गत किया जायेगा। उसके स्थान पर किसी अन्य अधिकारी द्वारा प्रमाण-पत्र निर्गत नहीं किया जायेगा।
2. प्रमाण-पत्र देने के पूर्व यह आवश्यकतानुसार तहसरलदार/एस.डी.एम./अपर जिलाधिकारी/बैंक अधिकारी अथवा किसी अन्य अधिकारी से जाँच कराकर रिपोर्ट प्राप्त कर सकते हैं।
3. संबंधित व्यक्ति से स्वघोषणा शपथ-पत्र भी ले सकते हैं।
4. यह प्रमाण पत्र सामान्यतः दो वर्ष के लिए मान्य होगा। यदि इससे पूर्व कोई महत्वपूर्ण विक्रय आदि होता है अथवा सम्पत्ति में परिवर्तन होता है या कमी आती है तो संबंधित व्यक्ति का यह उत्तरदायित्व होगा कि इसकी सूचना वह जिला मजिस्ट्रेट/कलेक्टर तथा संबंधित विभाग के अधिकारी को देगा और प्रमाण-पत्र में संशोधन जारी किया जायेगा।
5. इस प्रमाण-पत्रों की प्रविष्टि जिलाधिकारी कार्यालय में एक अलग रजिस्टर में विधिवत अंकित की जायेगी और निर्गत प्रमाण-पत्र की एक प्रमाणित फोटो प्रति रजिस्टर में अवश्य रखी जायेगी।
6. इस प्रमाण-पत्र के निर्गत करने अथवा निरस्त करने के संबंध में अंतिम निर्णय संबंधित जिला मजिस्ट्रेट/कलेक्टर का होगा।
7. संबंधित व्यक्ति द्वारा पासपोर्ट साइज का अपना नवीनतम फोटोग्राफ, जो राजपत्रित अधिकारी द्वारा प्रमाणित हो, हैसियत प्रमाण-पत्र के ऊपर निर्धारित स्थान पर चस्पा किया जायेगा।

FORM T-6

शपथ-पत्र

समक्ष: सक्षम प्राधिकारी, नगर निगम

मैं श्री/श्रीमती उम्र वर्ष
पुत्र/पति/पत्नी श्री/श्रीमती
निवासी स्थाई पता.....

राजपत्रित अधिकारी
द्वारा प्रमाणित पासपोर्ट
साइज का नवीनतम
फोटोग्राफ चस्पा किया
जाय

... का/की निवासी हूँ। मैं शपथपूर्वक निम्न घोषण करता/करती हूँ।

1. मैं ए/बी/सी/डी श्रेणी का पंजीकृत ठेकेदार हूँ /नहीं हूँ। (विभाग द्वारा निर्गत श्रेणी सम्बन्धी प्रमाण पत्र संलग्न किया जाय) मेरे पास पर्याप्त चल और अचल सम्पत्ति है और व्यवसायिक रूप से मैं सम्बन्धित विभाग के कार्यों को पूरा करने के लिये सक्षम और समर्थ हूँ। मेरे पास आवश्यक मशीनें और उपकरण आदि भी हैं अथवा मैंने उनके संबंध में आवश्यक लीज अग्रीमेन्ट निविदा में संलग्न कर दिया है। मुझे इस कार्य का पर्याप्त अनुभव है।
2. यह कि विभाग द्वारा (कार्य का विवरण लिखा जाय)
.....कार्य कराने की निविदा निर्गत की गयी है, उसके लिये मैं विभाग द्वारा निर्धारित प्रारूप पर निविदा कर रहा/रही हूँ।
3. मेरे द्वारा दिये जा रहे प्रमाण पत्र, चरित्र प्रमाण पत्र/हैंसियत प्रमाण पत्र/आयकर प्रमाण पत्र/व्यापार कर प्रमाण पत्र/बिड सिक्योरिटी प्रमाण पत्र/बिड कैपिसिटी प्रमाण पत्र जमानत धनराशि आदि का प्रमाण पत्र तथा अन्य सुसंगत अभिलेख आदि मूल रूप में निविदा पत्र के साथ संलग्न कर दिये गये हैं।
4. मेरा पैन नं० है।
5. मेरे विरुद्ध आपराधिक मुकदमों का विवरण निम्न है—
 - I. मुकदमा नं०
 - II. धारायें
 - III. थाना
 - IV. जनपद
 - V. न्यायालय (जहां मुकदमा चल रहा है)
6. मैं विभाग अथवा राज्य सरकार के अन्य विभागों द्वारा ब्लैक लिस्टेड ठेकेदार की श्रेणी में नहीं आता हूँ/ आती हूँ। मैं अपराधिक गतिविधियों, माफिया तथा गैंगेस्टर गतिविधियों और संगठित अपराध करने की गतिविधियों और असामाजिक कार्यों आदि में लिप्त नहीं हूँ। मैं माफिया और अपराधी नहीं हूँ। मेरा चाल-चलन कार्य तथा आचरण उत्तम है।
7. मेरे विरुद्ध किसी भी जनपद तथा प्रदेश में कोई भी मुकदमा दर्ज नहीं है।

8. यदि ठेका प्राप्त करने के पश्चात् मेरे विरुद्ध माफिया गतिविधियों/असामाजिक गतिविधियों एवं संगठित आपराधिक गतिविधियों में लिप्त होने के बारे में कोई शिकायत प्रमाणित पाई जाती है तो सक्षम अधिकारी को यह अधिकार होगा कि वह मेरा ठेका/अनुबन्ध निरस्त कर दे, इस पर मुझे कोई आपत्ति नहीं होगी। मेरे द्वारा यदि विभाग, राज्य सरकार के विरुद्ध कोई आपराधिक कृत्य किया जाता है अथवा सरकारी धन का गबन किया जाता है तो सक्षम प्राधिकारी को यह अधिकार होगा कि वह मेरे विरुद्ध आपराधिक मुकदमा नियमों के अन्तर्गत दर्ज करायेंगे।
9. मैं अनुबन्ध की शर्तों के अनुसार समय से पूरी गुणवत्ता के साथ तथा निर्धारित विशिष्टियों के अनुरूप कार्य पूरा करूँगा/ करूँगी।
10. मेरा कार्य एवं आचरण उत्तम है।
11. मैं शपथकर्ता घोषणा करता/करती हूँ कि मेरा स्थाई पता और अस्थायी पता निम्न प्रकार है—
अ— स्थाई पता (दूरभाष सहित)
ब— अस्थायी पता (दूरभाष सहित)
12. मैं शपथ पूर्वक घोषण करता/करती हूँ कि मैं उपरोक्त पते पर रहता/रहती हूँ तथा विभाग द्वारा प्रदान किये गये कार्य को पूरा होने तक मेरे किसी भी पते में सामान्यतया कोई परिवर्तन नहीं होगा, यदि अपरिहार्य परिस्थितियों में किसी पते में परिवर्तन होता है तो इसकी सूचना मैं मुख्य अभियन्ता/नगर आयुक्त, नगर निगमको दूँगा/दूँगी।
13. मैं यह भी घोषणा करता/करती हूँ कि विभाग के जिस कार्य के लिये मेरे द्वारा ठेका लिया जा रहा है, उसके साप्रेक्ष्य चल एवं अचल सम्पत्ति का हैसियत प्रमाण पत्र जिला मजिस्ट्रेट/कलेक्टर द्वारा प्राप्त मूल के रूप में संलग्न किया जा रहा है। यह भी घोषणा करता/करती हूँ कि इस हैसियत प्रमाण पत्र का उपयोग अन्य कार्यों के लिये नहीं किया जायेगा।
14. मैं अपनी पूर्ण जानकारी में, पूरे होशो हवास में, स्वस्थ चित्त से तथा पूरी सत्यनिष्ठा एवं स्वेच्छा से यह शपथ पत्र लिख दे रहा/रही हूँ। ईश्वर मेरी मदद करे।

शपथकर्ता का पूरा हस्ताक्षर

THIS PAGE HAS BEEN INTENTIONALLY KEPT BLANK

SECTION 3:- CONDITIONS OF CONTRACT

CONDITIONS OF CONTRACT

A. GENERAL CONDITION OF CONTRACT

1. Definitions

1.1. Terms which are defined in the Contract Data are not also defined in the Conditions of Contract but keep their defined meanings. Capital initials are used to identify defined terms.

Act or Electricity Act, 2003 shall mean the Electricity Act, 2003 and include any modifications, amendments and substitution from time to time;

Adjudicator (synonymous with **Dispute Review Expert**) is the person appointed jointly by the Employer and the Contractor to resolve disputes in the first instance, as provided for in Clauses 24 and 25. The name of the Adjudicator is defined in the Contract Data.

Appropriate Commission shall mean the Uttar Pradesh Power Corporation Limited (UPPCL)

Bill of Quantities means the priced and completed Bill of Quantities forming part of the Bid.

Company shall mean a body corporate incorporated in India under the Companies Act, 1956 or the Companies Act, 2013 or Cooperative Societies Registered under Cooperative Societies Act, 1984, as applicable;

Compensation Events are those defined in Clause 44 hereunder.

Completion Date is the date of completion of the Works as certified by the Engineer in accordance with Sub Clause 55.1.

Consents, Clearances and Permits shall mean all authorizations, licenses, approvals, registrations, permits, waivers, privileges, acknowledgements, agreements, or concessions required to be obtained from or provided by any concerned authority for the purpose of setting up of the generation facilities and/or supply of power line;

Contract is the contract between the “Employer” and the “Contractor” to execute, complete and maintain the works till the completion of Defect Liability Period. It consists of the documents listed in clause 2.3.

Contract Data defines the documents and other information which comprise the Contract.

Contractor is a person or corporate body whose Bid to carry out the Works has been accepted by the Employer.

Contractor's Bid is the completed Bidding document submitted by the Contractor to the Employer and includes Technical and Financial bids.

Contract Price is the price stated in the Letter of Acceptance and thereafter as adjusted in accordance with the provisions of the Contract.

Days are calendar days; **months** are calendar months.

Defect is any part of the Works not completed in accordance with the Contract.

Defects Liability Period is the period named in the Contract Data and calculated from the Completion Date

Discom or DISCOM shall refer to Dakshinanchal Vidyut Vitran Nigam Limited, Kanpur Electricity Supply Company Limited, Madhyanchal Vidyut Vitran Nigam Limited, Paschimanchal Vidyut Vitran Nigam Limited, Purvanchal Vidyut Vitran Nigam Limited and Uttar Pradesh Power Corporation Limited (UPPCL).

Employer is the party who will employ the Contractor to carry out the Works.

Engineer is the person named in the Contract Data (or any other competent person appointed and notified to the contractor to act in replacement of the Engineer) who is responsible for supervising the Contractor, administering the Contract, certifying payments due to the Contractor, issuing and valuing Variations to the Contract, awarding extensions of time, and valuing the Compensation Events.

Equipment is the Contractor's machinery and vehicles brought temporarily to the site to construct the works.

Initial Contract Price is the Contract Price listed in the Employer's Letter of Acceptance.

Intended Completion Date is the date on which it is intended that the Contractor shall complete the Works. The Intended Completion Date is specified in the Contract Data. The Intended Completion Date may be revised only by the Engineer by issuing an extension of time.

Materials are all supplies, including consumables, used by the contractor for incorporation in the Works.

Plant is any integral part of the Works which is to have a mechanical, electrical, electronic or chemical or biological function.

Routine Maintenance is the maintenance of works for five years as specified in the Contract Data.

The **Defect Liability Period (DLP)** of the entire works is of 5 years with routine maintenance as per SOP and maintenance manual.

Site is the area defined as such in the Contract Data.

Specification means the Specification of the Works included in the Contract and any modification or addition made or approved by the Engineer.

Start Date is given in the Contract Data. It is the date when the Contractor shall commence execution of the works. It does not necessarily coincide with any of the Site Possession Dates.

ST&DU or State Transmission & Distribution Utility shall mean the Board or the Government Company notified by the respective State Government under Sub-Section I of Section 39 of the Electricity Act, 2003.

Sub-Contractor is a person or corporate body who has a Contract with the Contractor to carry out a part of the construction work and/or routine maintenance in the Contract, which includes work on the Site.

Tax means and includes a tax, duty, rate, toll, fee etc. levied by the central or state Govt. or Local authorities under laws of India.

Temporary Works are works designed, constructed, installed, and removed by the Contractor which are needed for the construction or installation of the Works.

Variation is an instruction given by the Engineer, which varies the Works.

Works are what the Contract requires the Contractor to construct, install, and turn over to the Employer, as defined in the Contract Data. Routine maintenance is defined separately.

2. Interpretation

- 2.1. In interpreting these Conditions of Contract, singular also means plural, male also means female or neuter, and the other way around. Headings have no significance. Words have their normal meaning under the language of the Contract unless specifically defined. The Engineer will provide instructions clarifying queries about the Conditions of Contract.
- 2.2. If sectional completion is specified in the Contract Data, references in the Conditions of Contract to the Works, the Completion Date, and the Intended Completion Date apply to any Section of the Works (other than references to the Completion Date and Intended Completion date for the whole of the Works).
- 2.3. The documents forming the Contract shall be interpreted in the following order of priority:

- (1) Agreement
- (2) Letter of Acceptance, notice to proceed with the works
- (3) Contractor's Bid
- (4) Contract Data
- (5) Conditions of Contract including Special Conditions of Contract
- (6) Specifications
- (7) Drawings
- (8) Bill of quantities and
- (9) any other document listed in the Contract Data as forming part of the Contract.

3. Language and Law

3.1 The language of the Contract and the law governing the Contract are stated in the Contract Data.

3.2 The language for the formal correspondences are stated in the Contract Data.

4. Engineer's Decisions

4.1 Except where otherwise specifically stated, the Engineer will decide contractual matters between the Employer and the Contractor in the role representing the Employer.

4.2 Except as expressly stated in the Contract, the Engineer shall not have any authority to relieve the Contractor of any of his obligations under the contract.

5. Delegation

5.1. The Engineer may delegate any of his duties and responsibilities to other people except to the Adjudicator after notifying the Contractor and may cancel any delegation after notifying the Contractor.

6. Communications

6.1. All Certificate, notices or instructions to be given to the Contractor by Employer / Engineer shall be sent on the address or contact details given by the Contractor in Section 6- Form of Bid. The address and contact details for communication with the

Employer/ Engineer shall be as per the details given in bid document. Communications between parties that are referred to in the conditions shall be in writing. The Notice sent by Facsimile (fax) or other electronic means (email) shall be effective on confirmation of the transmission. The Notice sent by Registered post or Speed post shall be effective on delivery or at the expiry of the normal delivery period as undertaken by the postal service.

7. Sub-contracting

7.1. The Contractor may sub-contract any portion of work, upto a limit specified in Contract Data, with the approval of the Engineer but may not assign the Contract without the approval of the Employer in writing. Sub-contracting does not alter the Contractor's obligations.

8. Other Contractors

8.1. The Contractor shall cooperate and share the Site with other contractors, public authorities, utilities, and the Employer between the dates given in the Schedule of other Contractors. The Contractor shall as referred to in the Contract Data, also provide facilities and services for them as described in the Schedule. The employer may modify the schedule of other contractors and shall notify the contractor of any such modification.

9. Personnel

9.1. The Contractor shall employ the key personnel named in the Schedule of Key Personnel as referred to in the Contract Data to carry out the functions stated in the Schedule or other personnel approved by the Engineer. The Engineer will approve any proposed replacement of key personnel only if their qualifications, abilities, and relevant experience are substantially equal to or better than those of the personnel listed in the Schedule.

9.2. If the Engineer asks the Contractor to remove a person who is a member of the Contractor's staff or his work force stating the reasons the Contractor shall ensure that the person leaves the Site within seven days and has no further connection with the work in the Contract.

10. Employer's and Contractor's Risks

10.1. The Employer carries the risks which this Contract states are Employer's risks, and the Contractor carries the risks which this Contract states are Contractor's risks.

11. Employer's Risks

11.1. The Employer is responsible for the excepted risks which are (a) in so far as they directly affect the execution of the Works in India, the risks of war, hostilities, invasion, act of foreign enemies, rebellion, revolution, insurrection or military or usurped power, civil war, riot commotion or disorder (unless restricted to the Contractor's employees), and contamination from any nuclear fuel or nuclear waste or radioactive toxic explosive, or (b) a cause due solely to the design of the Works, other than the Contractor's design.

12. Contractor's Risks

12.1. All risks of loss of or damage to physical property and of personal injury and death which arise during and in consequence of the performance of the Contract other than the excepted risks are the responsibility of the Contractor.

13. Insurance (Contractors All Risk Policy)

13.1. The Contractor shall provide, in the joint names of the Employer and the Contractor, insurance cover (Contractors All Risk Policy) from the Start Date to the end of the Defects Liability Period, in the amounts and deductibles stated in the Contract Data for the following events which are due to the Contractor's risks:

- a. loss of or damage to the Works, Plant and Materials;
- b. loss of or damage to Equipment;
- c. loss of or damage of property (except the Works, Plant, Materials and Equipment) in connection with the Contract; and
- d. personal injury or death.

13.2. Policies and certificates for insurance shall be delivered by the Contractor to the Engineer for the Engineer's approval before the Start Date. All such insurance shall provide for compensation to be payable in the types and proportions of currencies required to rectify the loss or damage incurred.

13.3. If the Contractor does not provide any of the policies and certificates required, the Employer may affect the insurance which the Contractor should have provided and recover the premiums the Employer has paid from payments otherwise due to the Contractor or, if no payment is due, the payment of the premiums shall be a debt due.

13.4. Alterations to the terms of an insurance shall not be made without the approval of the Engineer.

13.5. Both parties shall comply with any conditions of the insurance policies.

13.6. In any case, the Contractor shall keep the Employer indemnified from any such losses.

14. Site Investigation Reports

14.1. The Contractor is advised to visit the site and get any investigation done at his own, while preparing the Bid.

15. Queries about the Contract Data

15.1. The Engineer will clarify queries on the Contract Data.

16. Contractor to Construct the Works

16.1. The Contractor shall construct and install the Works in accordance with the Specification and Drawings.

17. The Works to be completed by the Intended Completion Date

17.1. The Contractor may commence execution of the Works on the Start Date and shall carry out the Works in accordance with the programme submitted by the Contractor, as updated with the approval of the Engineer, and complete them by the Intended Completion Date.

18. Approval by the Engineer

18.1. The Contractor shall submit Specifications and Drawings showing the proposed Temporary Works to the Engineer, who is to approve them if they comply with the Specifications and Drawings.

18.2. The Contractor shall be responsible for design of Temporary Works.

18.3. The Engineer's approval shall not alter the Contractor's responsibility for design of the Temporary Works.

18.4. The Contractor shall obtain approval of third parties to the design of the Temporary Works where required.

18.5. All Drawings prepared by the Contractor for the execution of the temporary or permanent Works, are subject to prior approval by the Engineer before their use.

19. Safety

19.1. The Contractor shall be responsible for the overall safety of all activities on the Site during the construction period to pass the traffic without any obstruction.

20. Discoveries

20.1. Anything of historical or other interest or of significant value unexpectedly discovered on the Site is the property of the Employer. The Contractor is to notify the Engineer of such discoveries and carry out the Engineer's instructions for dealing with them.

21. Possession of the Site

21.1. The Employer shall give possession of all parts of the Site to the Contractor. If possession of a part is not given by the date stated in the Contract Data the Employer is deemed to have delayed the start of the relevant activities.

22. Access to the Site

22.1. The Contractor shall allow the Engineer and any person authorized by the Engineer access to the Site, to any place where work in connection with the Contract is being carried out or is intended to be carried out and to any place where materials or plant are being manufactured / fabricated / assembled for the works.

23. Instructions

23.1. The Contractor shall carry out all instructions of the Engineer pertaining to works which comply with the applicable laws where the Site is located.

23.2. The Contractor shall permit the Employer to inspect the Contractor's accounts and records relating to the performance of the Contractor and to have them audited by auditors appointed by the Employer, if so required by the Employer.

24. Disputes

24.1. If the Contractor believes that a decision taken by the Engineer was either outside the authority given to the Engineer by the Contract or that the decision was wrongly taken, the decision shall be referred to the Dispute Review Expert within 15 days (subjected to latest clause) of the notification of the Engineer's decision.

25. Procedure for Disputes

25.1. The official appointed by URIDA/Employer shall give a decision in writing within **15 days** of receipt of a notification of a dispute.

25.2. Deleted.

25.3 The arbitration shall be conducted in accordance with the arbitration procedure stated in the Special Conditions of Contract.

26. Replacement of Dispute Review Expert

26.1. Deleted

B. TIME CONTROL

27. Programme

27.1. Within the time stated in the Contract Data the Contractor shall submit to the Engineer for approval a Programme showing the general methods, arrangements, order and timing for all the activities in the Works along with monthly cash flow forecast. *After the completion of the construction works, the programme for the Routine Maintenance Work, showing the general methods, arrangements, order and timing for all the activities involved in the Routine Maintenance will also be submitted by the Contractor to the Engineer for approval. The programme for Routine Maintenance will be submitted in each year for the period of Maintenance.*

27.2. An update of the Programme shall be a programme showing the actual progress achieved on each activity and the effect of the progress achieved on the timing of the remaining work including any changes to the sequence of the activities.

27.3. The Contractor shall submit to the Engineer, for approval, an updated Programme at intervals no longer than the period stated in the Contract Data. If the Contractor does not submit an updated Programme within this period, the Engineer may withhold the amount stated in the Contract Data from the next payment certificate and continue to withhold this amount until the next payment after the date on which the overdue Programme has been submitted.

27.4. The Engineer's approval of the Programme shall not alter the Contractor's obligations. The Contractor may revise the Programme and submit it to the Engineer again at any time. A revised Programme is to show the effect of Variations and Compensation Events.

28. Extension of the Intended Completion Date

28.1. The Engineer shall extend the Intended Completion Date if a Compensation Event occurs or a Variation is issued which makes it impossible for Completion to be achieved by the Intended Completion Date without the Contractor taking steps to accelerate the remaining work and which would cause the Contractor to incur additional cost.

28.2. The Engineer shall decide whether and by how much to extend the Intended Completion Date within 30 days of the Contractor asking the Engineer for a decision upon the effect of a Compensation Event or Variation and submitting full supporting information. If the Contractor has failed to give early warning of a delay or has failed to cooperate in dealing with a delay, the delay by this failure shall not be considered in assessing the new Intended Completion Date.

28.3. The Engineer shall within 14 days of receiving full justification from the contractor for extension of Intended Completion Date refer to the Employer for his decision. The Employer shall in not more than 21 days communicate to the Engineer the acceptance or otherwise of the Engineer's decision. If the Employer fails to give his acceptance, the Engineer shall not grant the extension and the contractor may refer the matter to the Dispute Review Expert under Clause 24.1.

28.4. **Force Majeure (FM):** Conditions beyond control of either parties like war, hostility, acts of public enemy, civil commotion, sabotage, serious loss or damage by fire, explosions, epidemics, strikes, lockouts or acts of God come under the legal concept of Force Majeure (FM). Delays in performance of contractual obligations under influence of FM conditions are condonable by the other party without any right to termination or damages, provided, notice of the happening of any such event is given by the affected party to the other within 30 (thirty) days from the date of occurrence. Works under the contract shall be resumed as soon as practicable after such event has come to an end or ceased to exist. However, if such event continues for a period exceeding 120 days, either party may at its option terminate the contract by giving notice to the other party.

28.5. Delays in Execution:

- i. A work may be completed ahead of schedule or delayed due to unforeseen fortuitous circumstances, extra effort or developments beyond the control of the procuring entity or the tenderer and it is sometimes difficult to apportion credit or responsibility. The contractor may experience delay or disruption due to his own actions or inaction, those of his sub-contractor or other contractors, those of the procuring entity or the engineer, or other causes. Such delays expose the non-performing party to various sanctions under the contract. These sanctions include extension of time, damages or default termination of the contract. While examining the request of the contractor for extension of time, the engineer shall consider all circumstances and categorise the delays as follows:
 - a. **Excusable delays** - Force Majeure (FM), that is, acts of God, abnormal weather, floods, and so on, applies;
 - b. **Compensable delays** – or Compensation Events, which put full burden of responsibility on the Procuring Entity as covered in the GCC; and
 - c. **Inexcusable delay** (contractor's own faults), which puts the full burden of responsibility on the contractor.
 - d. **Concurrent delays** - when two or more events responsible for delay overlap each other. The delays may be attributable to the Procuring Entity or the contractor or none, and fall in above categories. The eligibility for extension of time (EOT) should

be determined by plotting each contributing concurrent delay on the critical path. The Procuring Entity/TIA should see that the concurrent delays do not result in unnecessary extra extension of time.

- ii. Once the delay is categorised, it should then be determined not only whether the contractor is eligible for time extension and/ or monetary relief but also whether sanctions, such as Liquidated Damage (LD) or default termination, can be imposed on the contractor.

29. Deleted.

30. Delays Ordered by the Engineer

30.1. The Engineer may instruct the Contractor to delay the start or progress of any activity within the Works.

31. Management Meetings

31.1. The Engineer may require the Contractor (all partners, in case of JV) to attend a management meeting. The business of a management meeting shall be to review the plans for the remaining work and to deal with matters raised in accordance with the early warning procedure.SSS

31.2. The Engineer shall record the business of management meetings and is to provide copies of his record to those attending the meeting and to the Employer. The responsibility of the parties for actions to be taken is to be decided by the Engineer either at the management meeting or after the management meeting and stated in writing to all who attended the meeting.

32. Early Warning

32.1. The Contractor is to warn the Engineer at the earliest opportunity of specific likely future events or circumstances that may adversely affect the quality of the work, increase the Contract Price or delay the execution of works. The Engineer may require the Contractor to provide an estimate of the expected effect of the future event or circumstance on the Contract Price and Completion Date. The estimate is to be provided by the Contractor as soon as reasonably possible.

32.2. The Contractor shall cooperate with the Engineer in making and considering proposals for how the effect of such an event or circumstance can be avoided or reduced by anyone involved in the work and in carrying out any resulting instruction of the Engineer.

C. QUALITY CONTROL

33. Identifying Defects

33.1. The Engineer shall check the Contractor's work and notify the Contractor for any Defects which are found. Such checking shall not affect the Contractor's responsibilities. The Engineer may instruct the Contractor to uncover and identify for any Defect and test any work that Engineer considers that it may have a Defect.

34. Tests

34.1. If the Engineer instructs the Contractor to carry out a test not specified in the Specification to check whether any work has a Defect and the test shows that it does, the Contractor shall pay for the test and any samples, if there is no Defect then such test shall be a compensation Event.

During the execution of the project, routine tests as per technical specifications shall be conducted at specified intervals to ensure quality and integrity, encompassing material testing, structural integrity checks, and compliance verification. The Contractor shall maintain a comprehensive test register documenting all tests conducted, and before proceeding with subsequent stages, approval from the Employer for previous test results shall be obtained.

In order to control the quality of work, a Quality Control field laboratory shall be established by Contractor in respective Nagar Nigam with comprising of multi-disciplinary professionals / engineers and necessary test equipment's to cover all types of quality control works pertaining to the project.

35. Correction of Defects

35.1. The Engineer shall give notice to the Contractor of any Defects before the end of the Defects Liability Period, which begins at Completion and is defined in the Contract Data. The Defects Liability Period shall be extended for as long as Defects remain to be corrected.

35.2. Every time notice of a Defect is given, the Contractor shall correct the notified Defect within the length of time specified by the Engineer's notice.

35.3. **Correction of Defects noticed during the Defects Liability Period and removal of deficiencies in Routine Maintenance of Roads for five years**

- a. The Engineer shall give notice to the Contractor of any Defects before the end of the Defects Liability Period, which begins from the Completion Date of works of construction and ends after five years. The Defects Liability Period shall be extended for as long as the Defects remain to be corrected.
- b. The Engineer shall give notice to the Contractor of any Defects before the end of the maintenance period, which begins from the Completion Date of the Defect Liability Period and ends after five years. The maintenance period shall be extended for as long as the Defects remain to be corrected.

- c. Every time notice of Defect/Defects is given, the Contractor shall correct the notified Defect/Defects within the duration of time specified by the Engineer's notice.
- d. The Contractor shall do the routine maintenance of roads, including pavement, road sides, cross drains including surface drains and other components indicated in scope of work to the required standards and in the manner as defined in Clause 1.1 and keep the entire road surface and structure in defect free condition during the entire maintenance period which begins from the Completion Date and ends after five years.
- e. In compliance to Programme of Routine maintenance work (as per clause 27.1) submitted by the contractor, he shall carry out monthly inspection of roads under maintenance, based on which, he shall submit monthly bills.

The maintenance standards shall meet the following minimum requirements and shall fulfil the criteria, which has been elaborated in SOP and maintenance manual with frequency and activity to be carried out.

- f. To fulfil the objectives laid down in sub clauses 35.3.d and 35.3.e above, the Contractor shall undertake detailed inspection of the roads at least once in a month. The Engineer can increase this frequency in case of emergency. The Contractor shall forward to the Engineer, the record of inspection and rectification each month. The Contractor shall pay particular attention on those road sections, which are likely to be damaged or inundated during rainy season.
- g. The Engineer may issue notice to the Contractor to carry out removable of defects and deficiencies in maintenance of defects, if any, noticed in his inspection, or brought to his notice. The Contractor shall remove the defects within the period specified in the notice and submit to the Engineer a compliance report. In any case the rectification shall be done within 15 days. If the Contractor fails to rectify the defects noticed by the Engineer within the specified period it will cause the breach of contract and suitable action shall be taken against the contractor as per specified clauses.
- h. Any instructions issued by the Departmental Officer/Quality Control Engineer during concurrence of contract or during defect liability period shall be binding upon the contractor.
- i. **The Contractor shall maintain power line (underground) under the supervision of respective substation Engineer-in-Charge as mentioned in the Contract data.**

36. Uncorrected Defects

36.1. If the Contractor has not corrected a Defect within the time specified in the Engineer's notice, the Engineer will assess the cost of having the Defect corrected, and the Contractor will pay this amount.

D. COST CONTROL

37. Bill of Quantities

37.1. The Bill of Quantities shall contain items for the construction, installation, testing, commissioning work and Routine maintenance work to be done by the Contractor.

37.2. The Bill of Quantities is used to calculate the Contract Price. The Contractor is paid for the quantity of the work done at the rate in the Bill of Quantities for the construction works. The payment for routine maintenance of road to the contractor is performance based.

38. Changes in the Quantities

Deleted

39. Variations

39.1 All Variations shall be included in updated Programmes produced by the Contractor.

39.2 The Engineer shall, having regard to the scope of the Works and the sanctioned estimated cost, have power to order, in writing, Variations within the scope of the Works, he considers necessary during the progress of the Works. Such Variations shall form part of the Contract and the Contractor shall carry them out and include them in updated Programmes produced by the Contractor. Oral orders of the Engineer for Variations, unless followed by written confirmation, shall not be taken into account.

39.3 Any Extra items and items to be deleted shall be treated as 100% variations. Prior approval of such items from Employer is mandatory.

Variation shall be sanctioned as per the latest circular which will be issued by URIDA/ competent authority from time to time.

40. Payments for Variations

40.1. If the quantity of work for any BOQ item is varied, it will not constitute a variation for the purpose of payment to the contractor, at a rate other than the one mentioned in the Agreement.

40.2. If the items for Variation are not specified in the Bill of Quantities, the Engineer shall derive the rate for such variation item from similar items in the Bill of Quantities.

40.3. If the rate for Variation item cannot be determined in the manner specified in Clause 40.2, the Contractor shall, within 14 days of the issue of order of Variation work, inform the

Engineer the rate which he proposes to claim, supported by analysis of the rates. The Engineer shall assess the quotation and determine the rate based on prevailing market rates within one month of the submission of the claim by the Contractor. As far as possible, the rate analysis shall be based on the standard data book and the relevant schedule of rates of the state. The recommendation of the Engineer on the rate so determined shall be submitted to the employer for approval. The decision of the employer shall be final and binding on the Contractor.

41. Cash Flow Forecasts

41.1. When the Programme is updated, the contractor is to provide the Engineer with an updated cash flow forecast.

42. Payment Certificates

42.1. The Contractor shall submit to the Engineer monthly statements of the estimated value of the work completed less the cumulative amount certified previously.

42.2. The Engineer shall check the Contractor's monthly statement within 14 days and certify the amount to be paid to the Contractor after taking into account any credit or debit for the month in question in respect of materials for the works in the relevant amounts and under conditions set forth in sub-clause 51(3) of the Contract Data.

42.3. The value of work executed shall be determined by the Engineer Incharge

42.4. The value of work executed shall comprise the value of the quantities of the items in the Bill of Quantities completed.

42.5. The value of work executed shall include the valuation of Variations and Compensation Events. (asked to check compensation events)

42.6. The Engineer may exclude any item certified in a previous certificate or reduce the proportion of any item previously certified in any certificate in the light of later information.

42.7. The payment to the Contractor will be as follows for routine maintenance:

The payment to be made to the Contractors for routine maintenance of roads is as follows and as per circulars given time to time.

Payment for the routine maintenance is performance based and lump sum as provided in the contract. For assessing the performance of roads and payment, the Contractor should submit monthly bills of maintenance on, through regular routine inspection **(RI)** and

Performance Evaluation (**PE**) by the engineer. The details of RI, marking system in PE and payment methodology is given in note below. The detailed marking system is given in contract data, clause 4 (vi).

- (1) Payment for routine maintenance will be performance based. For certification of payment of routine maintenance, the engineer shall determine whether the contractor has actually achieved compliance to the Service Quality Level (and other requirements) specified in the SOP and maintenance manual, with reference to 100-point (hundred point) performance indexes assigned to various maintenance activities as given in the contract data and the engineer shall certify the amount to be paid to the contractor. If contractor has not corrected a Defect pertaining to the Defects Liability Period or attended maintenance work under clause 35 of these conditions, to the required standard and performance index is below 80 points (eighty points) no payment will be released for that period even if such maintenance is attended in subsequent months. If performance index is 100 points full payment, at the approved rate, shall be released. If performance index is between 80 to 100, proportionate deduction in payment will be made for the works not attended during that period.
- (2) For performance evaluation and payment of routine maintenance individual road shall be the unit. Evaluation shall be done separately for every km or part thereof (segment wise) and weighted average of marks obtained shall be considered while making payment.
- (3) If any two segments get less than 80 marks or any particular segment continuously gets less than 80 marks, the payment for whole road shall be denied. Details are as below.

Note: The Routine Inspection and performance evaluation of road will be done for the whole road.

ROUTINE INSPECTIONS

- (1) Every road must be inspected for Routine Inspection (RI) at least once in every month. (Monthly frequency)
- (2) Routine inspection can be carried out by any of the PIU officers including Sub Engineer /JE/AE/DE/AEE/EE or equivalent.
- (3) Deleted.
- (4) For the purpose of RI, each road shall be divided into segments of one kilometer

or part thereof. Complete road length shall be compulsorily inspected during a routine inspection.

- (5) For each segment two geo-tagged and time-stamped photographs shall be documented for each segment. The chainages for capturing photographs shall be system generated to ensure randomness.
- (6) Deleted.
- (7) Deleted.

PERFORMANCE EVALUATION (PE)

- (1) Every road must be evaluated at least once in every month. (Monthly frequency)
- (2) PE can be carried out by any of the PIU officers including Sub Engineer/ JE/ AE/DE/AEE or equivalent.
- (3) For the purpose of PE, each road shall be divided into segments of one kilometer or part thereof. Based on the grading of RI and along with photographs documented during RI, every segment is given marks out of 100 on the parameters fixed for PE. The weighted average marks are then evaluated for the entire road.
- (4) All the PE conducted need to be finalized by the respective PIU-in- charge.
- (5) While finalizing PE, PIU-in- charge may change the marks given to the road by the inspecting officer, along with mentioning the reasons for the change made.
- (6) Criteria for Payment based on the marks obtained in PE is as follows:
 - a) If the weighted average marks for the entire road is 100 then full payment will be done.
 - b) If the weighted average marks for the entire road is between 80 and 100, then proportionate payment will be done. For e.g if the marks obtained is 88 out of 100 then 88% of the amount of bill raised will be paid.
If the weighted average marks for the entire road is less than 80 then no payment will be done for the entire road.
 - c) Deleted.
 - d) If any two segments of a road get less than 80 marks in the same PE, then no payment will be done for the entire road.
 - e) If any particular segment of a road gets less than 80 marks in two consecutive PE, then no payment will be done for the entire road.
- (6) The Contractor shall submit to the Engineer a bill every month for the routine maintenance of the roads from the date the maintenance period starts i.e. from completion date as defined in Section 3, Clause 1.1, it will be supported with a copy of the record of the Contractor's monthly inspection and other instructions received from the Engineer.

- (7) The payment will be made quarterly for the monthly bills received and as certified by the Engineer based on performance by the Contractor.
- (8) The contractor shall submit monthly bills by the 10th day of the next month and if the bill for a month is not received from the Contractor, he forfeits his right for the payment and no payment shall be due to the contractor.

On submission of timely bills, engineer to certify the quality and actions taken as per clause 35.3.g by the contractor, by way of Routine inspection and Performance evaluation, marking system as explained herein before, the frequency of RI and PE is every two months and payment of bills is six monthly and Engineer should ensure not delay of RI and PE-

- (9) If the Contractor has failed to carry out the maintenance within the period specified by the Engineer, no payment of any kind will be due to the Contractor for that month.

43. Payments

37.1. Payments shall be adjusted for deductions for advance payments, retention, other recoveries in terms of the contract and taxes at source, as applicable under the law. The Employer shall pay upon the submission of bill and satisfactory execution of work the Contractor the amounts certified by the Engineer within 28 days of the date of each certificate.

43.2. Deleted

43.3 Deleted.

44. Compensation Events

44.1. The following are Compensation Events unless they are caused by the Contractor:

- (a) The Employer does not give access to a part of the Site by the Site Possession Date stated in the Contract Data.
- (b) The Employer modifies the schedule of other contractors in a way, which affects the work of the contractor under the contract.
- (c) The Engineer orders a delay or does not issue drawings, specifications or instructions required for execution of works on time.
- (d) The Engineer instructs the Contractor to uncover or to carry out additional tests upon work, which is then found to have no Defects.
- (e) The Engineer does not approve of a subcontract to be let, within 15 days.

- (f) Ground conditions are substantially more adverse than could reasonably have been assumed before issuance of Letter of Acceptance from the information issued to Bidders (including the Site Investigation Reports), from information available publicly and from a visual inspection of the site.
- (g) The Engineer gives an instruction for dealing with an unforeseen condition, caused by the Employer, or additional work required for safety or other reasons.
- (h) Other contractors, public authorities utilities or the Employer does not work within the dates and other constraints stated in the Contract, and they cause delay or extra cost to the Contractor.
- (i) The advance payment is delayed, beyond 28 days after receipt of application and bank guarantee.
- (j) The effect on the Contractor of any of the Employer's Risks.
- (k) The Engineer unreasonably delays issuing a Certificate of Completion.
- (l) Other Compensation Events listed in the Contract Data or mentioned in the Contract.

44.2. Deleted.

44.3. Deleted.

44.4. Deleted.

45. Tax

45.1. The rates quoted by the Contractor shall be deemed to be inclusive all taxes but exclusive of G.S.T, which shall be paid extra as applicable.

46. Currencies

46.1. All payments shall be made in Indian Rupees.

47. Price Adjustment

Deleted

48. Retention

48.1. The Employer shall retain from each payment due to the Contractor, the proportion stated in the Contract Data until Completion of the whole of the Works.

48.2. On Completion of the whole of the Works half the total amount retained is repaid to the Contractor and half when the Defects Liability Period has passed and the Engineer has certified that all Defects notified by the Engineer to the Contractor before the end of this period have been corrected.

48.3. On completion of the whole works, the contractor may substitute retention money with an "on demand" Bank guarantee.

49. Liquidated Damages

49.1. The Contractor shall pay liquidated damages to the Employer at the rate per day stated in the Contract Data for each day that the Completion Date is later than the Intended Completion Date (for the whole of the works or the milestone as stated in the contract data). The total amount of liquidated damages shall not exceed the amount defined in the Contract Data. The Employer may deduct liquidated damages from payments due to the Contractor. Payment of liquidated damages does not affect the Contractor's liabilities.

49.2. If the Intended Completion Date is extended after liquidated damages have been paid, the Engineer shall correct any overpayment of liquidated damages by the Contractor by adjusting the next payment certificate. The Contractor shall be paid interest on the over payment calculated from the date of payment to the date of repayment at the rates specified in Sub Clause 43.1.

49.3. If the contractor fails to comply with the time for completion as stipulated in the tender, then the contractor shall pay to the employer the relevant sum stated in the Contract Data as Liquidated damages for such default and not as penalty for everyday or part of day which shall elapse between relevant time for completion and the date stated in the taking over certificate of the whole of the works on the relevant section, subject to the limit stated in the contract data.

The employer may, without prejudice to any other method of recovery deduct the amount of such damages from any monies due or to become due to the contractor. The payment or deduction of such damages shall not relieve the contractor from his obligation to complete the works on from any other of his obligations and liabilities under the contract.

49.4. If, before the Time for Completion of the whole of the Works or, if applicable, any Section, a Taking - Over Certificate has been issued for any part of the Works or of a Section, the liquidated damages for delay in completion of the remainder of the Works or of that Section shall, for any period of delay after the date stated in such Taking-Over Certificate, and in the absence of alternative provisions in the Contract, be reduced in the proportion which the value of the part so certified bears to the value of the whole of the Works or Section, as applicable. The provisions of this Sub-Clause shall only apply to the rate of liquidated damages and shall not affect the limit thereof.

50. Deleted.**51. Advance Payment**

51.1. The Employer shall make advance payment (not to be paid in less than two installments except in special circumstances for which the reasons to be recorded in writing) to the Contractor of the amounts stated in the Contract Data by the date stated in the Contract Data, against provision by the Contractor of an Unconditional Bank Guarantee in a form and by a bank acceptable to the Employer in amounts and currencies equal to be at least 110% of the advance payment. The guarantee shall remain effective until the advance payment has been repaid, but the amount of the guarantee shall be progressively reduced by the amounts repaid by the Contractor. The mobilization advance would be deemed as interest bearing advance at an interest rate of 10% to be compounded quarterly.

51.2. The Contractor is to use the advance payment only to pay for Equipment, Plant and Mobilization expenses required specifically for execution of the Works. The Contractor shall demonstrate that advance payment has been used in this way by supplying copies of invoices or other documents to the Engineer.

51.3. The advance payment shall be repaid by deducting proportionate amounts from payments otherwise due to the Contractor, following the schedule of completed percentages of the Works on a payment basis. No account shall be taken of the advance payment or its repayment in assessing valuations of work done, Variations, price adjustments, Compensation Events, or Liquidated Damages.

51.4. **Secured Advance-** No Secured Advances will be given.

52. Securities

52.1. The Performance Security (including additional security for unbalanced bids) shall be provided to the Employer no later than the date specified in the Letter of Acceptance and shall be issued in an amount and form and by a bank or surety acceptable to the Employer, and denominated in Indian Rupees. The Performance Security shall be valid until a date 28 days from the date of expiry of Defects Liability Period and the additional security for unbalanced bids shall be valid until a date 28 days from the date of issue of the certificate of completion.

53. Deleted.**54. Cost of Repairs**

54.1. Loss or damage to the Works or Materials to be incorporated in the Works between the Start Date and the end of the Defects Correction periods shall be remedied by the Contractor

at the Contractor's cost if the loss or damage arises from the Contractor's acts or omissions.

E. FINISHING THE CONTRACT

55. Completion

55.1. The Contractor shall request the Engineer to issue a Certificate of Completion of the Works and the Engineer will do so upon deciding that the Work is completed.

56. Taking Over

56.1. The Employer shall take over the Site and the Works within seven days of the Engineer issuing a certificate of Completion.

57. Final Account

57.1. The Contractor shall supply to the Engineer a detailed account of the total amount that the Contractor considers payable under the Contract before the end of the Defects Liability Period. The Engineer shall issue a Defect Liability Certificate and certify any final payment that is due to the Contractor within 56 days of receiving the Contractor's account if it is correct and complete. If it is not, the Engineer shall issue within 56 days a schedule that states the scope of the corrections or additions that are necessary. If the Final Account is still unsatisfactory after it has been resubmitted, the Engineer shall decide on the amount payable to the Contractor and issue a payment certificate, within 56 days of receiving the Contractor's revised account.

58. Operating and Maintenance Manuals

58.1. If "as built" Drawings and/or operating and maintenance manuals are required, the Contractor shall supply them by the dates stated in the Contract Data.

58.2. If the Contractor does not supply the Drawings and/or manuals by the dates stated in the Contract Data, or they do not receive the Engineer's approval, the Engineer shall withhold the amount stated in the Contract Data from payments due to the Contractor.

59. Termination

59.1. The Employer or the Contractor may terminate the Contract if the other party causes a fundamental breach of the Contract.

59.2. Fundamental breaches of Contract include, but shall not be limited to the following:

- (a) the Contractor stops work for 28 days when no stoppage of work is shown on the current Programme and the stoppage has not been authorized by the Engineer;
- (b) the Engineer instructs the Contractor to delay the progress of the Works and the instruction is not withdrawn within 28 days;
- (c) the Employer or the Contractor is made bankrupt or goes into liquidation other than for a reconstruction or amalgamation;
- (d) a payment certified by the Engineer is not paid by the Employer to the Contractor within 56 days of the date of the Engineer's certificate;
- (e) the Engineer gives Notice that failure to correct a particular Defect is a fundamental breach of Contract and the Contractor fails to correct it within a reasonable period of time determined by the Engineer;
- (f) the Contractor does not maintain a security which is required;
- (g) the Contractor has delayed the completion of works by the number of days for which the maximum amount of liquidated damages can be paid as defined in the Contract data; and
- (h) if the Contractor, in the judgment of the Employer has engaged in corrupt or fraudulent practices in competing for or in executing the Contract.

For the purpose of this paragraph: "corrupt practice" means the offering, giving, receiving or soliciting of anything of value to influence the action of a public official in the procurement process or in contract execution. "Fraudulent practice" means a misrepresentation of facts in order to influence a procurement process or the execution of a contract to the detriment of the Borrower, and includes collusive practice among Bidders (prior to or after bid submission) designed to establish bid prices at artificial non-competitive levels and to deprive the Borrower of the benefits of free and open competition."

59.3. When either party to the Contract gives notice of a breach of contract to the Engineer for a cause other than those listed under Sub Clause 59.2 above, the Engineer shall decide whether the breach is fundamental or not.

59.4. Notwithstanding the above, the Employer may terminate the Contract for convenience.

59.5. If the Contract is terminated the Contractor shall stop work immediately, make the Site safe and secure and leave the Site as soon as reasonably possible.

60. Payment upon Termination

60.1. If the-Contract is terminated because of a fundamental breach of Contract by the Contractor, the Engineer shall issue a certificate for the value of the work done less advance payments received up to the date of the issue of the certificate, less other recoveries due in terms of the contract, less taxes due to be deducted at source as per applicable law and less the percentage to apply to the work not completed as indicated in the Contract Data. Additional Liquidated Damages shall not apply. If the total amount due to the Employer exceeds any payment due to the Contractor the difference shall be a debt payable to the Employer.

60.2. If the Contract is terminated at the Employer's convenience or because of a fundamental breach of Contract by the Employer, the Engineer shall issue a certificate for the value of the work done, the cost of balance material brought by the contractor and available at site, the reasonable cost of removal of Equipment, repatriation of the Contractor's personnel employed solely on the Works, and the Contractor's costs of protecting and securing the Works and less advance payments received up to the date of the certificate, less other recoveries due in terms of the contract and less taxes due to be deducted at source as per applicable law.

61. Property

61.1. All materials on the Site, Plant, Equipment, Temporary Works and Works are deemed to be the property of the Employer, if the Contract is terminated because of a Contractor's default.

62. Release from Performance

62.1. If the Contract is frustrated by the outbreak of war or by any other event entirely outside the control of either the Employer or the Contractor the Engineer shall certify that the Contract has been frustrated. The Contractor shall make the Site safe and stop work as quickly as possible after receiving this certificate and shall be paid for all work carried out before receiving it and for any work carried out afterwards to which commitment was made.

F. SPECIAL CONDITIONS OF CONTRACT

63. Labour

The Contractor shall, unless otherwise provided in the Contract, make his own arrangements for the engagement of all staff and labour local or other, and for their payment, housing, feeding and transport.

The Contractor shall, if required by the Engineer, deliver to the Engineer a return in detail, in such form and at such intervals as the Engineer may prescribe, showing the staff and the numbers of the several classes of labour from time to time employed by the Contractor on the Site and such other information as the Engineer may require.

64. Compliance with Labour Regulations:

During continuance of the contract, the Contractor and his sub-contractors shall abide at all times by all existing labour enactments and rules made thereunder, regulations, notifications and bye laws of the State or Central Government or local authority and any other labour law (including rules), regulations, bye laws that may be passed or notification that may be issued under any labour law in future either by the State or the Central Government or the local authority. Salient features of some of the major labour laws that are applicable to construction industry are given below. **The Contractor shall keep the Employer indemnified in case any action is taken against the Employer by the competent authority** on account of contravention of any of the provisions of any Act or rules made thereunder, regulations or notifications including amendments. If the Employer is caused to pay or reimburse, such amounts as may be necessary to cause or observe, or for non-observance of the provisions stipulated in the notifications/bye laws/Acts/Rules/regulations including amendments, if any, on the part of the Contractor, the Engineer/Employer shall have the right to deduct any money due to the Contractor including his amount of performance security. The Employer/Engineer shall also have right to recover from the Contractor any sum required or estimated to be required for making good the loss or damage suffered by the Employer.

The employees of the Contractor and the Sub-Contractor in no case shall be treated as the employees of the Employer at any point of time.

65. SALIENT FEATURES OF SOME MAJOR LABOUR LAWS APPLICABLE TO ESTABLISHMENTS ENGAGED IN BUILDING AND OTHER CONSTRUCTION WORK.

- a) Workmen Compensation Act 1923 :- The Act provides for compensation in case of injury by accident arising out of and during the course of employment.
- b) Payment of Gratuity Act 1972 :- Gratuity is payable to an employee under the Act on satisfaction of certain conditions on separation if an employee has completed five (5) years' service or more on death, the rate of 15 days wages for every completed year of service. The Act is applicable to all establishments employing 10 or more employees.
- c) Employees P.F. and Miscellaneous Provision Act 1952 : The Act Provides for monthly contributions by the employer plus workers @ 10% or 8.33%. The benefits payable under the Act are:

- (i) Pension or family pension on retirement or death, as the case may be.
- (ii) Deposit linked insurance on the death in harness of the worker.
- (iii) Payment of P.F. accumulation on retirement/death etc.
- d) Maternity Benefit Act 1951:- The Act provides for leave and some other benefits to women employees in case of confinement or miscarriage etc.
- e) Contract Labour (Regulation & Abolition) Act 1970:- The Act provides for certain welfare measures to be provided by the Contractor to contract labour and in case the Contractor fails to provide, the same are required to be provided, by the Principal Employer by Law. The Principal Employer is required to take Certificate of Registration and the Contractor is required to take license from the designated Officer. The Act is applicable to the establishments or Contractor of Principal Employer, if they employ 20 or more contract labour.
- f) Minimum Wages Act 1948 :- The Employer is supposed to pay not less than the Minimum Wages fixed by appropriate Government as per provisions of the Act, if the employment is a scheduled employment. Construction of Buildings, Roads, Runways are scheduled employments.
- g) Payment of Wages Act 1936:- It lays down as to by what date the wages are to be paid, when it will be paid and what deductions can be made from the wages of the workers.
- h) Equal Remuneration Act 1979 :- The Act provides for payment of equal wages for work of equal nature to Male and Female workers and for not making discrimination against Female employees in the matters of transfers, training and promotions etc.
- i) Payment of Bonus Act 1965:- The Act is applicable to all establishments employing 20 or more employees. The Act provides for payments of annual bonus subject to a minimum of 8.33% of wages and maximum of 20% of wages to employees drawing Rs.3500/-per month or less. The bonus to be paid to employees getting Rs.2500/- per month or above upto Rs.3500/- per month shall be worked out by taking wages as Rs.2500/ -per month only. The Act does not apply to certain establishments. The newly set-up establishments are exempted for five years in certain circumstances. Some of the State Governments have reduced the employment size from 20 to 10 for the purpose of applicability of this Act.
- j) Industrial Disputes Act 1947 :- The Act lays down the machinery and procedure for resolution of Industrial disputes, in what situations a strike or lock-out becomes illegal and what are the requirements for laying off or retrenching the employees or closing down the establishment.
- k) Industrial Employment (Standing Orders) Act 1946 :- It is applicable to all establishments employing 100 or more workmen (employment size reduced by

some of the States and Central Government to 50). The Act provides for laying down rules governing the conditions of employment by the Employer on matters provided in the Act and get the same certified by the designated Authority.

- l) Trade Unions Act 1926:- The Act lays down the procedure for registration of trade unions of workmen and employers. The Trade Unions registered under the Act have been given certain immunities from civil and criminal liabilities.
- m) Child Labour (Prohibition & Regulation) Act 1986 :- The Act prohibits employment of children below 14 years of age in certain occupations and processes and provides for regulation of employment of children in all other occupations and processes. Employment of Child Labour is prohibited in Building and Construction Industry.
- n) Inter-State Migrant workmen's (Regulation of Employment & Conditions of Service) Act 1979 :- The Act is applicable to an establishment which employs 5 or more inter-state migrant workmen through an intermediary (who has recruited workmen in one state for employment in the establishment situated in another state). The Inter-State migrant workmen, in an establishment to which this Act becomes applicable, are required to be provided certain facilities such as housing, medical aid, travelling expenses from home upto the establishment and back, etc.
- o) The Building and Other Construction workers (Regulation of Employment and Conditions of Service) Act 1996 and the Cess Act of 1996 :- All the establishments who carry on any building or other construction work and employs 10 or more workers are covered under this Act. All such establishments are required to pay cess at the rate not exceeding 2% of the cost of construction as may be modified by the Government. The Employer of the establishment is required to provide safety measures at the Building or construction work and other welfare measures, such as Canteens, First-Aid facilities, Ambulance, Housing accommodations for workers near the work place etc. The Employer to whom the Act applies has to obtain a registration certificate from the Registering Officer appointed by the Government.
- p) Factories Act 1948 :- The Act lays down the procedure for approval of plans before setting up a factory, health and safety provisions, welfare provisions, working hours, annual earned leave and rendering information regarding accidents or dangerous occurrences to designated authorities. It is applicable to premises employing 10 persons or more with aid of power or 20 or more persons without the aid of power engaged in manufacturing process.

65. Provision of vehicle

Contractor have to provide one vehicle in good condition of hard top of make not before two years in proper running condition with maintenance of vehicle, all POL and driver with valid license to the department for which no extra payment will be made to contractor during execution of work.

66. Drawings and Photographs of the Works

- a. The Contractor shall do photography/video photography of the site firstly before the start of the work, secondly mid-way in the execution of different stages of work and lastly after the completion of the work. No separate payment will be made to the Contractor for this.
- b. The Contractor shall not disclose details of Drawings furnished to him and works on which he is engaged without the prior approval of the Employer in writing. No photograph of the works or any part thereof or plant employed thereon, except those permitted under clause 58.1, shall be taken or permitted by the Contractor to be taken by any of his employees or any employees of his sub-Contractors without the prior approval of the Employer in writing. No photographs/ Video photography shall be published or otherwise circulated without the approval of the Employer in writing.
- c. **The Apprentices Act, 1961**-The Contractor shall duly comply with the provisions of the Apprentices Act, 1961 (III of 1961), the rules made there under and the orders that may be issued from time to time under the said Act and the said Rules and on his failure or neglect to do so, he shall be subject to all liabilities and penalties provided by the said Act and said Rules

67. Green technologies

67.1 RECYCLING OF BITUMINOUS PAVEMENTS

Recommended practice for recycling of bituminous pavements as per IRC 120: 2015

67.2 CEMENT GROUTED BITUMINOUS MIX

Flexible pavements are the most common types of pavement used for highways in India and rest of the world. Bituminous wearing course of such pavements often suffer wet weather damage which gets aggravated in cities due to flooding during monsoon. The pavements at traffic intersections, parking places and bus stops are noticeably damaged due to frequent braking action and fuel spillage. So, there arises a need for durable wearing course which is (i)

strong enough to resist braking and accelerating effect of traffic (ii) fuel resistant (iii) impervious to water and (iv) moisture resistant. Research at IIT Kharagpur and at CSIR-CRRI has shown that open graded bituminous layer grouted with a cementitious grout can form a durable wearing course. Some other research Institute had developed similar product which has been used at a few locations in Kharagpur, Surat and Amravati. Flexible and Rigid pavements are common in India and now composite pavements are emerging.

The present guidelines deal with the design, preparation and application procedure for CGBM to be laid over bituminous surface. Almost single graded bituminous mix (having voids more than 25% which is more than the voids in traditional dense graded bituminous mixes) is paved and grouted with cement grout as under:

i) Mixed with optimum dose of bituminous binder (sometimes fibers may be added to prevent drain down) (ii) paved over a base (iii) compacted to design density (iv) filled with cementitious grout slurry (sufficiently flowable cement grout is applied on the compacted surface). This cement grout is primarily prepared by mixing suitable proportions of cement, fine sand and water. Other materials like fly ash, micro silica, super plasticizers, fibres etc. may be adequately and suitably added in order to improve the grout flowability and strength of grout.

CGBM is to be generally used as surface layer, but it also has potential to be used as base course

FOLLOW IRC:SP:125-2019 GUIDELINES FOR CEMENT GROUTE BITUMINOUS MIX SURFACING FOR URBAN ROADS.

67.2 WASTE PLASTIC ROADS

Use of Waste Plastics in Road Construction

Dry Process: In Dry process, shredded waste plastics are used as coating material for aggregates. Heated stone aggregate (170°C) coated with waste plastic is mixed with hot bitumen (160°C) and the mix is used for road laying.

The aggregate when coated with plastics improved its quality with respect to voids, soundness and moisture absorption and decreases porosity and thus the performance of the pavement is increased.

Wet Process: Plastic waste is ground and made into powder. Powdered plastic waste is added to the bitumen at 160°C. High shear blender is required to prepare plastic modified bitumen and specific chemical treatment may be required to restrict the phase separation.

IRC:SP:98-2013- GUIDELINES FOR THE USE OF WASTE PLASTIC IN HOT BITUMINOUS MIXES (DRY PROCESS) IN WEARING COURSES

67.3 CONVENTIONAL AND THIN WHITETOPPING

Whitetopping is defined as a Portland Cement Concrete (PCC) overlay constructed on the top of an existing bituminous pavement. Whitetopping is thus PCC resurfacing (overlay) as a rehabilitation or structural strengthening alternative on bituminous pavement. The PCC overlay may or may not be bonded to the layer below.

Whitetopping on existing bituminous pavements provides many additional benefits as compared to conventional bituminous overlay alternative. Some of the benefits are:

- Long life, low maintenance, low life-cycle cost, improved safety and environmental benefits.
- Bituminous overlays exhibit a more rapid loss of serviceability as compared to concrete whitetopping at some critical locations. The lives of successive bituminous overlays become progressively shorter after the first overlay.
- Deformation like rutting and cracking predominant in case of bituminous pavements is normally absent with concrete surfaces of whitetopping. This is particularly true in a hot climate like India.
- Conventional Whitetopping improves structural capacity of existing bituminous pavement, if built on a strong base course, and it impedes structural distresses.
- Whitetopping requires much less maintenance and as such involves much less frequent lane closures of road, as compared to bituminous surfaces.
- Whitetopping is quite cost-effective to tackle annual budget constraints and high traffic levels. It is, therefore, quite relevant to Indian conditions.
- Whitetopping can uniformly fill ruts in the wheel path of bituminous pavements more effectively because concrete is far more stiff and consistent at high temperature than bituminous mixes. Broadly, for similar reasons, the occurrence of cracks is also relatively much less in case of whitetopping.
- Concrete is relatively light in colour and hence concrete surface is more reflective to light, absorb less heat and reduce the urban heat island effect. Improved reflection of lights from vehicles enhances safety, lowers energy requirement of external lighting, lower contribution to heat in environment.
- Fuel consumption on concrete roads has been found to be less than the bituminous roads

FOLLOW IRC:SP:76-2015-GUIDELINES FOR CONVENTIONAL AND THIN WHITETOPPING.

Any other technology accredited by IRC may be considered as green technology for the similar work experience under Section 1 ITB, Cl. 4.5.

ARBITRATION (GCC Clause 25.3)

The procedure for arbitration will be as follows:

- 25.3 (a) In case of Dispute or difference arising between the Employer and a domestic contractor relating to any matter arising out of or connected with this agreement, such disputes or difference shall be settled in accordance with the Arbitration and Conciliation Act, 1996. The parties shall make efforts to agree on a sole arbitrator and only if such an attempt does not succeed and the Arbitral Tribunal consisting of 3 arbitrators one each to be appointed by the Employer and the Contractor and the third Arbitrator to be chosen by the two Arbitrators so appointed by the Parties to act as Presiding Arbitrator shall be considered. In case of failure of the two arbitrators appointed by the parties to reach upon a consensus within a period of 30 days from the appointment of the arbitrator appointed subsequently, the Presiding Arbitrator shall be appointed by the Indian Road Congress (IRC) empaneled list.
- (b) The Arbitral Tribunal shall consist of three Arbitrators one each to be appointed by the Employer and the Contractor. The third Arbitrator shall be chosen by the two Arbitrators so appointed by the Parties, and shall act a presiding arbitrator. In case of failure of the two arbitrators appointed by the parties to reach upon a consensus within a period of 30 days from the appointment of the arbitrator appointed subsequently, the Presiding arbitrator shall be appointed by the Indian Road Congress (IRC) empaneled list.
- (c) If one of the parties fails to appoint its arbitrator in pursuance of sub clause (a) and (b) above within 30 days after receipt of the notice of the appointment of its arbitrator by the other party, then the Indian Roads Congress shall appoint the arbitrator. A certified copy of the order IRC., making such an appointment shall be furnished to each of the parties.
- (d) Arbitration proceedings shall be held in India, and the language of the arbitration proceedings and that of all documents and communications between the parties shall be English.
- (e) The decision of the majority of arbitrators shall be final and binding upon both parties. The cost and expenses of Arbitration proceedings will be paid as determined by the arbitral tribunal. However, the expenses incurred by each party in connection with the preparation, presentation, etc. of its proceedings as also the fees and expenses paid to the arbitrator appointed by such party or on its behalf shall be borne by each party itself.
- (f) Performance under the contract shall continue during the arbitration proceedings and payments due to the contractor by the owners shall not be withheld, unless they are the subject matter of the arbitration proceedings.

THIS PAGE HAS BEEN INTENTIONALLY KEPT BLANK

SECTION 4:- CONTRACT DATA

CONTRACT DATA

Clause Reference
with respect
to section3

{Note for Procuring Entity: Text in grey italics font within square bracket [e.g., Mention ...] are just suggestions/ directions and must be replaced by applicable text - remove brackets and convert the font to regular and black. Delete the rows not required. Clauses other than those mentioned below may also be mentioned, if these need to be changed}

Note for Bidders: Following Special Conditions of Contract (SCC) shall apply for this procurement. These Special Conditions shall modify/ substitute/ supplement the corresponding (GCC) clauses as indicated below. Whenever there is any conflict between the provision in the GCC and that in the SCC, the provision contained in the SCC shall prevail.

Condition of Contract Clause No.	Topic	Conditions
[Cl.1.1]	The Authority	<i>Municipal Commissioner Name: Kanpur Municipal Corporation Address: Moti jheel Kanpur</i>
[Cl.1.1]	The Engineer	<i>Name: Chief Engineer Kanpur Municipal Corporation</i>
[Cl.1.1]	The Dispute Review Expert appointed by the Authority	<i>will be Provided By URIDA , Lucknow</i>
[Cl.1.1&35]	The substation Engineer in Charge	<i>Executive Engineer Kanpur Municipal Corportaion</i>
[Cl.1.1&35]	Defects Liability Period	<i>[5 Year from the date of Completion of Work]</i>
[Cl.1.1&35]	Routine Maintenance Period	<i>[5 Year from the date of Completion of Work]</i>
[Cl.1.1&35]	Period for Joint Inspection	<i>[1 Month or as per requirement assessed by the Engineer/Authority]</i>
[Cl. 27.3]	The amount to be withheld for late submission of an updated programme	<i>5 lakhs</i>
[Cl.1.1]	Start Date	<i>7 days from the date of issue of the Notice to proceed with the work.</i>
[Cl.1.1, 17&28]	Intended Completion Date	<i>15 months rom the date of issue of the Notice to proceed with the work.</i>
[Cl.2.2 & 49.1]	<i>Milestones (physical works):</i>	<i>Milestone 1 i.e.20.00% : .(25% of total time)</i>

		Milestone 2 i.e. 50.00%:(50% of total time) Milestone 3 i.e. 80.00%: (75% of total time) Milestone 4 i.e. 100.00%: (100% of total time)
[Cl. 1.1]	The Site	Baba Kuti intersection to Alankar Guest House (Length 2.34 km) via Sote Baba Mandir is being carried out, Under Zone -03
[Cl. 1.1]	The name and identification number of the Contract	133/CE/24-25
[Cl. 1.1]	The works consist of	the works shall, inter alia, include the following, as specified in Section V or as directed by the Authority
[Cl. 2.3(9)]	Work programmed and any other document to complete the work as per schedule	[Fill]
[Cl. 3.1]	The law which applies to the Contract	Law of Uttar Pradesh Government
[Cl. 3.1]	The language of the Contract documents	English
[Cl. 3.2]	The language for the formal correspondences	Hindi and English
[Cl. 7.1]	Limit of subcontracting	25% of the Initial Contract Price
[Cl. 8.1]	Schedule of other Contractor	[Fill]
[Cl. 9]	The Schedule of Key Personnel	As per Annex.-II to Section I
[Cl. 13]	Minimum insurance cover	Physical property, injury and death is Rs.5 lakhs per occurrence with the number of occurrences limited to four. After each occurrence, contractor will pay additional premium necessary to make insurance valid for four occurrences always.
[Cl. 21]	Site Possession Date	Date of issue of notice to proceed with the work
[Cl. 26]	Appointing Authority for the Dispute Review Expert	CEO, URIDA
[Cl. 27.1]	The period for submission of the programme for approval of Engineer	10 days from the issue of Letter of Acceptance

[Cl. 27.3]	The period between programme updates	One Month [may be amended as per requirement]
[Cl. 44]	The following events shall also be Compensation Events:	<ul style="list-style-type: none"> ● <i>Substantially adverse ground conditions encountered during the course of execution of work not provided for in the bidding document</i> ● <i>Removal of underground utilities detected subsequently (Remove if not mentioned in bidding document)</i> ● <i>Significant change in classification of soil requiring additional mobilisation by the contractor, e.g. ordinary soil to rock excavation,</i> ● <i>Removal of unsuitable material like marsh, debris dumps, etc not caused by the contractor</i> ● <i>Artesian conditions</i> ● <i>Seepage, erosion, landslide</i> ● <i>River training requiring protection of permanent work</i> ● <i>Presence of historical, archeological or religious structures, monuments interfering with the works</i> ● <i>Restriction of access to ground imposed by civil, judicial, or military authority</i>
[Cl. 46]	The currency of the Contract	Indian Rupees
[Cl. 48]	The proportion of payments retained (retention money)	5% from each bill subject to a maximum of 5% of final contract price.
[Cl. 49]	Amount of liquidated damages for delay in completion of works	<p><u>For Whole of work</u> (1/2000)th of the Initial Contract Price, rounded off to the nearest Thousand, per day.</p> <p>For sectional completion (wherever specified, in <i>Milestones (physical works)</i> (Cl.2.2 & 49.1) of Contract Data (1/200)th of initial contract price for 5 km section, rounded off to the nearest thousand per day.</p>

[Cl. 49]	Maximum limit of liquidated damage for delay in completion of work.	10% After 10% the bond will be terminated and securities will be forfeited and the works will be executed on the risks & cost of the contractor.	
[Cl. 51 & 52]	Amounts of the advance payment	Yes (The advance payment will be paid to the Contractor no later than 28 days after fulfillment of the below conditions).	
		<p>i. Mobilization</p> <p>10% of the Contract price</p> <p>On submission of unconditional Bank Guarantee, (to be drawn before the end of 20% of Contract period). The contractor may furnish four bank guarantees of 2.5% each, valid for full period.</p>	
		<p>ii. Equipment</p> <p>90% for new and 50% of depreciated value for old equipment. Total amount will be subject to a maximum of 5% of the Contract price.</p> <p>After equipment is brought to site (provided the Engineer is satisfied that the equipment is required for performance of the contract) and on submission of unconditional Bank Guarantee for amount of advance.</p>	
ii. Deleted	[Cl. 51]	Repayment of advance payment for mobilization and equipment:	The advance loan shall be repaid with percentage deductions from the interim payments certified by the Engineer under the Contract. Deductions shall commence in the next Interim Payment Certificate following that in which the total of all such payments to the Contractor has reached not less than 20 per cent of the Contract Price or 6 (Six) months from the date of payment of first instalment of advance, whichever period concludes earlier, and shall be made at the rate of 20 per cent of the amounts of all Interim Payment

		<p>Certificates until such time as the loan has been repaid, always provided that the loan shall be completely repaid prior to the expiry of the original time for completion pursuant to Clauses 17 and 28.</p> <p>The advance would be deemed as interest bearing advance at an interest rate of 10% to be compounded quarterly</p>
[Cl. 51.4]	Secured Advance	No Secured Advances will be given.
[Cl. 52]	The Securities shall be for the following minimum amounts equivalent as a percentage of the Contract Price:	<p>Performance Security for 5 per cent of contract price plus Rs.....</p> <p>(to be decided after evaluation of the bid) as additional security in terms of ITB Clause 29.5.</p> <p>The standard form of Performance Security acceptable to the Authority shall be an <u>unconditional</u> Bank Guarantee of the type as presented in Section 8 of the Bidding Documents</p>
[Cl. 58]	Schedule of Operating and Maintenance Manuals	<u>[As ascertained in Annexure 4]</u>
[Cl. 58]	The date by which "as-built" drawings (in scale as directed) in 2 sets are required	Within 28 days of issue of certificate of completion of whole or section of the work, as the case may be.
[Cl. 58]	The amount to be withheld for failing to supply "as built" drawings by the date required	Rs. One Lakhs.
[Cl. 59.2]	The following events shall also be fundamental breach of contract	The Contractor has contravened Sub-clause 7.1 and Clause 9 of GCC
[3, Cl. 60]	The percentage to apply to the value of the work not completed representing the Authority's additional cost for completing the Works	20 per cent

4. Routine Maintenance during five years after the Completion Date is defined in SOP and maintenance manual:

(i) Deleted.

(ii) Deleted.

(iii) Deleted.

(iv) Deleted.

(v) Deleted.

(Note: A periodical renewal is not part of routine maintenance).

(vi) The periodicity of routine maintenance activities shall be as follows, this is for guidance only, however, road is to be maintained in serviceable condition all the time and payment is performance based, as per performance evaluation and marks obtained.

Routine Maintenance Activities and their frequency with performance index (PI) –
Bituminous Road/ Cement Concrete Roads/ Paver Block Road

Performance Index (PI) Table

Sl. No.	Name of Item/ Activities	Frequency of operation in a year	Bituminous Road/ Cement Concrete Roads/ Paver Block Road
1.	Maintenance of Travel Lane	As mentioned in SOP and maintenance manual	30
2.	Maintenance of Street lighting & Maintenance of Landscape features	As mentioned in SOP and maintenance manual	15
3.	Maintenance of Storm water drains	As mentioned in SOP and maintenance manual	10
4.	Maintenance of Footpath and cycle track	As mentioned in SOP and maintenance manual	10
5.	Maintenance of power line (underground electrification)	As mentioned in SOP and maintenance manual	10
6.	Maintenance of Road signs & markings	As mentioned in SOP and maintenance manual	10
7.	Maintenance of (other) Utilities	As mentioned in SOP and maintenance manual	5
8.	Maintenance of Street furniture & Bus shelters	As mentioned in SOP and maintenance manual	5
9.	Maintenance of Bridges, culverts, structures	As mentioned in SOP and maintenance manual	5
Total			100

Note: Maintenance of Utilities refers to civil work of all utilities constructed by the contractor except storm water.

This page has been intentionally left blank.

SECTION 5:- SCOPE OF WORK & TECHNICAL SPECIFICATION

1. Project Background

Urban areas are known as the growth engines of the country. Uttar Pradesh has the highest number of urban bodies in India. The state is committed to achieve the target of "One Trillion Economy" by the year 2027 by strengthening the basic infrastructure, especially the urban basic infrastructure and enhance "Ease of Doing Business" and "Ease of Living". Roads are the most vital component of urban basic infrastructure. Most of the commercial and economic activities are conducted along the roads. Hence, integrated road network becomes one of the prime components of urban basic infrastructure. Due to increasing urbanization in the State, there is a great need to develop and enhance an integrated road network using innovative technology to reduce the burden of extra vehicles on the roads and to bring enhanced mobility in the means of transport. In the given context and to promote social and economic development in the State and encourage economic autonomy in ULBs through the development of roads, an incentive-based scheme "Chief Minister-Green Road Infrastructure Development Scheme- Urban (CM-GRIDS)" is being launched by the Urban Development Department. CM GRIDS aims to make the existing "Urban Road Improvement Scheme" being implemented from 2013-14, more effective. In urban areas, the development of roads of 45 meters or more width is generally done by the Public Works Department in the form of National Highway and State Highway and the development of roads of less than 10 meters width is done by the Finance Commission, Mukhyamantri Nagar Srujan Yojana (C M NSY) and Pt. Deen Dayal Upadhyaya Nagar Vikas Yojana etc. are done by the urban bodies as a component, but there is no dedicated plan for the development of roads between 10 m to 45 m wide , while the roads of the said width are the main routes of urban traffic and economic activities.

2. Scope of Work

Scope of work includes applying the design principles, objective and expected outcomes illustrated in drawings. The implementing agency (i.e contractor) shall review the design and details for betterments or improvements if any which may be incorporated to better achieve the employer's goals and objectives. These betterments, if any, shall be submitted by the Implementing Agency to the Employer for review and for the approval before the commencement of on ground working stage.

The Implementing Agency must make itself aware of general and specific site conditions, topography and any existing landscape prior to commencement of any works on site. The on-site execution scope of work comprises of preparation of detailed engineering design execution drawings, full, final and entire installation and completion of road works to a 'best practice standard' for such works, (inclusive of road surface, road section elements, hardscape, soft-scape, smart bus stops, street furniture, signage and street lighting) and associated landscape services (levelling, drainage etc.) based on the proposal design developed by the Employer Kanpur Municipal Corporation and the good for construction drawings provided by

them. The implementing agency shall ensure the handing over of the same in full accordance with the Employer's requirements.

The broad scope of works shall be as described below,

- i. GPR Survey (Ground penetrating radar), road survey report, traffic diversion plan, above ground utility shifting plan and invert levels of SWD (Storm Water Drain) pipes to be included in Contractor's scope of work in tender document.
- ii. Dismantling of existing Infrastructure including divider, footpaths, traffic island, Kerbs, drainage, road furniture, electrical overhead wiring poles transformers etc. which are fouling in the proposed work area. However, Kanpur Municipal Corporation will clear any encumbrances or encroachment and provide the full or partial area before start of dismantling to execute the work.
- iii. Removal/Replantation of trees if required.
- iv. Twice the number of trees to be planted with respect to the number of trees to be removed. Kanpur municipal Corporation to ensure compliance with NGT of any other Govt. Orders in this regard]
- v. Dispose of the dismantled materials to the location indicated by Kanpur municipal Corporation
- vi. Relaying of flexible / rigid pavement as per details provided in the design drawings and bill of quantities (BOQ) and as per the directions of the engineer in charge.
- vii. Construction of Footpaths.
- viii. Construction of intersections/Raised Pedestrian Crossings.
- ix. Providing Landscaping including the street furniture, tiling, grating, painting etc.,
- x. Providing Road Signage Boards including signage markings.
- xi. Constructions of Storm waters system as per the Final drawing.
- xii. Construction of DWC /HDPE/Other pipes laying both sides along the road as per Final drawing.
- xiii. Foundation, installation and pillars for the transformer, erection of poles and feeder etc. should be as per the requirements of the designs (Single line diagram) and as per the direction of Engineer in-charge and must coordinate with the concerned electricity department/ Contractor appointed by said department for the shifting of electrical utility lines.
- xiv. Provision of Earthling system.
- xv. Supply and Laying of underground LT/HT cables in duct/crossing pipes including but not limited to street lighting/Landscaping/footpaths/cycle track etc.
- xvi. Supply and laying of cable for underground LT/HT lines in duct/crossing pipes including but not limited to street lighting/ Landscaping/ Footpaths/cycle track etc.
- xvii. Supply, Installation, Testing and Commissioning of H Poles with all accessories, LT/HT cables, Transformer, RMU, Compact Switch Gear, Feeder pillars, Termination of Cables with termination kit.

- xviii. Supply, installation testing and Commissioning of H- Poles with all hardware accessories, cables, transformer, RMU, Compact switch gear, feeder and pillars for LT/HT line.
- a. The Shifting of the overground / underground utilities including Electric Pole, Light Pole, Transformer, Signal Pole, Camera Pole, Sign Board, OFC, Trees, Telephone Pole, Manhole, High Mast, Electric Junction Box, Telephone Box, Solar Light Pole, Water Pump, Tower as required and specified in BOQ and drawings and as per the direction of Engineer in Charge.

Note: Notwithstanding anything contains in this RFP, selected Contractor/selected bidder must submit all drawing and design dully vetted from IIT's /NIT's /IET, Lucknow along with final BOQ.

A. Road, Footpath and Allied works

- i. The cross section for the road was determined based on traffic studies.
- ii. All roads are proposed to have pedestrian footpath. Wherever the space constraints exist, shared spaces for both are proposed.
- iii. Raised pedestrian crossings are proposed to facilitate pedestrians to cross the road. (Amend as required)
- iv. For details on existing and proposed components, please refer to **Section 9** for sections, Plans and drawings.

B. Proposed Road Network

The roads which are to be upgraded have been demarcated and provided in the below map for reference

C. Scope of work for utility provision

It is proposed to have **Water Supply, Sewer Line, Telecom / OFC** (amend as per requirement) work below footpath as per drawings given by the authority. Where required, necessary manhole arrangement for every 50m interval (amend as per requirement of each utility) shall be provided for maintenance purpose, the schedule of **DI / CI / DWC / HDPE / Other Pipe** laying is as per design drawing.

Storm Water Drain - It is proposed to have storm water drain below road and edge of footpath as per drawings given by the authority. Necessary inlet arrangement at every XX m interval (Gully trap) shall be provided to collect and convey the surface water into the drain and necessary invert level, disposal point to be provided by the contractor. Manhole shall be provided at every XX m for efficient maintenance of drain.

Detailed design, levels and location of the above utilities will be provided in the Good for Construction (GFC) Drawings issued by Name of tender authority.

D. Scope of Work for Power Line

The Contractor's scope for this package shall include detailed engineering including revision and updating of all documents and drawings, preparation of documents and drawings for procurement etc., supply, installation, testing & commissioning of all new equipment's and dismantling of old materials at site as required for electrical line work, liasoning with URIDA, appropriate commission UPPCL and other government / statutory agencies / local authorities for getting their clearances, concurrences, approval etc. (as per Electricity Act 2003). For diversion of 132/220/400KV, 11/33/66KV, HT, LT & overhead Lines (ST&DU) to underground cabling system in distribution line (DISCOM). Also all associated work related to civil, structural, architectural works for the installation of electrical equipment's, foundations, Electrical Road Crossings (ERC), etc., as covered in the respective parts and also for completion of the subject job including but not limited to the following are included in the Contractor's scope.

- Supply, installation, testing and commissioning of following equipment as per SOR.
- Supply & installation of following equipment as per SOR.
- Excavation, Backfilling, Making of foundation & miscellaneous jobs as per SOR.
- Inspection, Testing & Commissioning
- Miscellaneous works including obtaining consents, clearance and permits.

Note:-

(1) The quantities, rate given in Cost schedule are tentative. Contractor shall take Employer's approval before ordering of the material.

(2) Unaccountable Wastage

- a. The contractor will be allowed un-accountable wastage and losses during erection not exceeding the following quantities

Insulators	1.00%
Conductor, Earthwire and cable	1.25%
Conductor, Earthwire and cable accessories (for underground line)	2.00%
- b. The Contractor shall make every effort to minimize the breakages, losses and wastage during erection & construction, of the Purchaser supplied items.
- c. The conductor length up to 50m will be treated as good and conductor length less than 50 meter will be treated as scrap/ wastage. On completion of work the contractor will return balance items over and above actually used on each line. Wastage shall also be returned either in damaged condition or otherwise, however should the necessity arise to deliver these items in excess of their permissible wastage, double the prevailing market cost of these shall be recovered from the Contractor's bills.
- d. Rates of recovery for empty conductor drum, empty earthwire drum not returned by the Contractor to purchaser shall be double the prevailing market

price at the time of actual recovery after taking into account permissible wastage.

- (3) Clearances required from the State Government and concerned Urban Local Bodies
- a. All approvals, permits and clearances required for setting up of the Project including those required from State Government and local bodies shall be in the scope of the Bidder.

E. Pre Construction Stage

- i. The Employer shall arrange for a kick-off meeting with all the pertinent stakeholders - Traffic Police, Police, PWD, KESCO, Jalkal, Jalnigam, UPMRC, CUGL, Telecom etc. before the construction commencement and will obtain all necessary permissions for the construction activity.
- ii. The contractor shall submit Dismantling and Construction plan and Construction Methodology to Kanpur Municipal Corporation and get it approved prior commencing the works.
- iii. The contractor shall check the topographical survey and mark the proposed design on ground (with total station survey equipment) and immediately bring to the notice of Kanpur Municipal Corporation about the changes and variations based on site conditions with respect to the drawings provided in the tender. After acceptance and approval of the proposed changes the Kanpur Municipal Corporation will make the necessary modifications to the drawings and furnish the contractor with the final Good for Construction Drawings for execution.
- iv. Prior to commencing the demolition and construction works, the contractor shall assess the appropriate locations of all the underground utilities by using the state of the art technologies (Total Station Equipment / GPR Surveys / etc) and mark the same on ground for approval by Kanpur Municipal Corporation.
 - a. In case there are discrepancies between the alignments of utilities shown on the drawing and those that exist on the ground, the contractor shall immediately inform the client in writing to resolve the matter. Kanpur Municipal Corporation will take the necessary action for the same within 7 days from the date of letter receipt from the contractor.
- v. At no point of time, shall the contractor completely block the flow of on-going traffic. Additionally, no disruptions shall be allowed with regards to access to the properties, shops, entry/exits along the road. And no modifications may be made to the extents of the Right Of Way (ROW).
 - a. Where disruptions are unavoidable, the contractor must make necessary plans / take necessary steps to ensure minimal inconvenience (or provide alternate paths / routes) to the public and the same should be approved by Kanpur Municipal Corporation, prior to initiating the work.

- vi. Contractor shall prepare a traffic management plan and have it approved by Kanpur Municipal Corporation. The traffic management plan should clearly indicate how the traffic will be managed during the construction and have it approved by the Kanpur Municipal Corporation, Traffic Police and/or any other stakeholders as identified by Name of tendering authority.
- vii. The contractor shall submit the safety and quality assurance, control plan within 30 days from Date of LOI to Kanpur Municipal Corporation, and have it approved.
- viii. Allotment of all lines shall be done after confirmation of availability of land for respective substation, transmission, distribution and underground cable power line. However allotment of lines for which substation land or area is available or lines which is being constructed between existing substations shall be done immediately. The work shall be started immediately after allotment of line.
- ix. Other necessary provisions of rules & regulation of Indian Govt, URIDA and UPPCL state government/ central government relating to navigations, railways, Road and PTCC etc. are to be complied by the contractor.

F. Construction Phase

- i. Kanpur Municipal Corporation shall approve the Good for Construction (GFC) drawing and furnish the same to the contractor after making necessary changes, if required, and accordingly the contractor will start the construction work within 15 days from the date of approval of GFC drawing.
- ii. Contractor shall follow all aspects of labor regulations, health and safety during the contract;
- iii. Relocation of utilities shall be done by relevant agencies like Jal Nigam etc. However, where the bidder is required to relocate the utilities, the cost of relocation shall be borne by the Nagar Nigam/ URIDA. The relocation charges shall be approved by Nagar Nigam/ URIDA as per the prevailing departmental rate plus minus the % bid rate.
- iv. Site clearing and grubbing within the Right of Way (ROW).
- v. Shifting or transplanting of trees if required.
- vi. Excavation for utilities, roadworks, and footpaths cycle tracks, landscaping, and street lighting etc. including filling / re-filling with suitable material as approved by the Engineer in Charge.
- vii. Removal of existing pavement and stack or dispose the excavated road materials as indicated by the Engineer in Charge.
- viii. All dismantled materials shall be stacked or disposed by the bidder as directed by the Engineer in Charge.

- ix. Construction storm water system including all manholes, Manholes covers, connecting to the existing lines as indicated in the drawings and specifications provided in the tender.
- x. Construction of ducts/HDPE pipes for laying of LT/HT, OFC cables including all manholes, manhole covers, connecting to the existing lines as indicated in the drawings and specifications provided in the tender.
- xi. Construction of main carriage way, kerbs, medians, raised pedestrian crossings, intersection improvements, footpaths, landscape and road works as per drawings and specifications provided in the tender.
- xii. Supply and fixing of railing/guard rails along the median and roadsides.
- xiii. Providing thermoplastic pavement marking, pavement marker (glow studs), road furniture (signs road studs, median marker, pedestrian crossings, rumble strips, solar powered traffic blinkers, delineators);
- xiv. Provision of kerbs and road markings with thermoplastic material, Traffic signs (Informatory, Mandatory, Cautionary) with retro-reflecting sheeting, delineators and other road furniture;
- xv. Provision of Utility ducts/ RCC pipes for Road Crossings.
- xvi. Foundation for transformers, Poles, Feeder Pillars, Service Feeder Pillars etc. as per the requirements of the design and as per direction of Engineer in Charge.
- xvii. Supply and Laying of DWC/HDPE/Other pipes / duct / crossing pipes etc. as per the requirements of the design and as per direction of Engineer in Charges.
- xviii. Deleted
- xix. Survey (Preliminary & Final) tower, transformer, electric pole, HT,LT, distribution and underground line spotting and preparing single line diagram, peg marking, foundation, installation and earthwire, if any tackwelding including bolts and nuts, fixing of accessories installation of hardware, insulators strings and HDPE pipe, for underground cable, distribution and transmission line with the help of respective substation.
- xx. Unloading and tacking delivery of all materials to be supplied by the bidders, transporting to depots, sorting and stacking them in proper storage sheds and yards provided by the contractor, safe custody of all materials.
- xxi. Tools and plants required for construction of the distribution line at various stages shall be arranged by the contractor at his own cost.

G. Post Construction Phase

- i. Clearing of site and handing over of the works;
- ii. Submission of "As Built Drawings" and other related documents to Kanpur Municipal Corporation.
- iii. Rectification of the defects in the completed works during the Defects Liability Period;

-
- iv. Routine and periodic maintenance in accordance with the details of maintenance activity elaborated in Annexure IV.
 - v. Soil investigation, auger, soil, metal, sand, concrete and earth resistivity test etc. whenever/wherever required by the Nagar Nigam/ URIDA/Sub-Stations.
 - vi. Foundation, Operation, Maintenance, Installation testing and commissioning for underground line by electrical safety department.
 - vii. Line Inspection by Electrical Safety Department U.P.
 - a. All suppliers of electricity including generating companies, transmission companies and distribution companies shall designate an Electrical Safety Officer for ensuring observance of safety measures specified under these regulations in their organization for construction, installation, operation and maintenance of all power line like- sub-stations, transmission and distribution lines.
 - b. The Electrical Safety Officer designated under sub-regulation, shall ensure periodic inspection of such construction, installation, operation and maintenance of all power line like- sub-stations, transmission and distribution lines. Get them tested and keep a record there of and such records shall be made available to the Electrical Inspector if and when required.
 - c. Plan for area of supply to be made and kept open for inspection. - (I) The licensee shall, after commencing to supply electricity, forthwith cause a plan, to be made in electronic form, of the area of supply, and shall cause to be marked there on the alignment and at the case of transmission, distribution and underground line works, the approximate depth below the surface of all the existing an electrical utility supply lines, street distributing boxes and other technical works. Duly corrected so as to show the electric supply lines, street distributing boxes and other works for the time being in position and shall also, if so required by an Electrical Inspector, cause to be made sections showing the approximate level of all his existing underground distribution line works other than service lines.
 - d. General safety requirements. Pertaining to construction, installation, protection, operation and maintenance of all electrical supply lines and apparatus.-
 - i. All electric supply lines and apparatus shall be of sufficient rating for power, insulation and estimated fault current and of sufficient mechanical strength, for the duty cycle which they may be required to perform under the environmental conditions of installation, and shall be constructed, installed, protected, worked and maintained in such a manner as to ensure safety of human beings, animals and property.
 - ii. Save as otherwise provided in these regulations, the relevant code of practice of the Bureau of Indian Standards or National. Electrical Code, if any, may be followed to carry out the purposes of this regulation and
-

in the event of any inconsistency, the provisions of these regulations shall prevail.

- iii. The material and apparatus used shall conform to the relevant specifications of the Bureau of Indian Standards or International Electrical-Technical Commission where such specifications have already been laid down.
- iv. The contractor shall ensure that all electric supply lines, wires, fittings and apparatus belonging to him or under his control, Which are on a consumer's premises, are in a safe-condition and in all respects fit for supplying electricity and the supplier shall take precautions to avoid danger arising on such premises from such supply' lines, wires, fittings and apparatus
- e. The line is ready for charging only after inspection by the electrical safety department.

H. Safety, vehicle breakdowns and accidents

The Contractor shall ensure safe conditions for the users, and in the event of unsafe conditions, lane closures, diversions, vehicle break downs and accidents, they shall follow the relevant operating procedures for removal of obstruction and debris without delay. Such procedures shall conform to the provisions of this Agreement, Applicable Laws, Applicable Permits and Good Industry Practice.

The Contractor shall promptly remove any debris from the Project Road to enable safe movement of traffic and shall report all accidents to the Kanpur Municipal Corporation and police forthwith.

I. Kanpur Municipal Corporation's right to take remedial measures

In the event the Contractor does not repair the Project Road (Smart Road) or any part thereof during the Defect Liability Period or fails to commence remedial works within the time provided in this document, the Kanpur Municipal Corporation shall, without prejudice to its rights under this Agreement, be titled to undertake such remedial measures at the cost of the Contractor, and to recover its cost from the Contractor.

J. Details of Roads in kanpur municipal corporation to be taken up under CMGRIDS

The details of various roads that are to be undertaken under this contract are shown in the below table;

S.No	Package No.	Road Name (including from & to)	Length (KM)	Average ROW
1.	KMC/CMG01	NH 19 via Rajaram Intersection to Hamirpur main road (4.30 KM) in front of Namak Factory Intersection, Under Zone-02	4.30	24m

2.	KMC/CMG 02	Karahi Road to Hamirpur Road metro line via Rambagh Tiraha (6.05 KM) Under Zone -03	6.05	24m
3.	KMC/CMG 03	Baba Kuti intersection to Alankar Guest House (Length 2.34 km) via Sote Baba Mandir is being carried out, Under Zone - 03 and Bagiya Crossing Kalyanpur to Kesa Office under is being carried out Under Zone -06	2.34	24m
4.	KMC/CMG 04	Bagiya Crossing Kalyanpur to Kesa Office under is being carried out Under Zone -06	1.15	30M

K. Drawings Design

At the tender stage, Kanpur Municipal Corporation will provide the following indicative drawings & these drawings are enclosed in the RFP. However, the contractor is required to execute the work only as per the final design and Good for Construction (GFC) drawings approved by Kanpur Municipal Corporation. The contractor shall not commence the work unless Good for Construction drawings are not approved by the Name of tender authority.

- i. Existing layout plan of roads and utilities.
- ii. Proposed layout plan of roads.
- iii. Proposed Cross section of road, storm water drainage and DWC / HDPE / other pipes / ducts for various utilities.
- iv. Single line diagram for electrical line.

To download the drawings please visit the following link: _____

THIS PAGE HAS BEEN INTENTIONALLY KEPT BLANK

SECTION 6:- FORM OF BID

FORM OF BID

[The bidder shall fill in and submit the bid form with the bid]

Description of the Works to be filled by Nagar Nigam:

To :

Address :

1. We offer to execute the Works described above and remedy any defects therein in conformity with the conditions of Contract, specification, drawings, Bill of Quantities and Addenda for the sum(s) of

As per BOQ

(_____)

2. We undertake, if our Bid is accepted, to commence the Works as soon as is reasonably possible after the receipt of the Engineer's notice to commence, and to complete the whole of the Works comprised in the Contract within the time stated in the document.
3. We agree to abide by this Bid for the period of * days from the date fixed for receiving the same, and it shall remain binding upon us and may be accepted at any time before the expiration of that period.
4. Unless and until a formal Agreement is prepared and executed this Bid, together with your written acceptance thereof, shall constitute a binding contract between us.
5. We understand that you are not bound to accept the Lowest or any tender you may receive.

Dated this day of 20.....

Signature in the capacity of
duly authorized to sign bids for and on behalf of _____

(in block capitals or typed)

Address

_____Witness

Address

Occupation

THIS PAGE HAS BEEN INTENTIONALLY KEPT BLANK

SECTION 7:- BILL OF QUANTITIES

BILL OF QUANTITIES

Preamble

The Bill of Quantities shall be read in conjunction with the Instructions to Bidders, Conditions of Contract, Specifications and Drawings.

- 7.1 For the construction of works, the quantities given in the Bill of Quantities are estimated and are given to provide a common basis for bidding. The basis of payment will be the actual quantities of work ordered and carried out, as measured by the Contractor and verified by the Engineer and valued
- (a) at percentage rate above or below or at par of the Schedule of Rates as tendered by the Contractor in Indian Rupees.
 - (b) Where there is a discrepancy between the rate in figures and words, the rate in words will govern as explained in ITB Clause _____. [Note: delete this point if the E-tender system automatically populates the amount in words from the amount in figures].
- 7.2 For the routine maintenance of roads, there is lump sum amount for each year of maintenance for entire stretch. The payments will be based on satisfactory performance of routine maintenance activities.
- 7.3 The rates and prices tendered in the priced Bill of Quantities shall, except in so far as it is otherwise provided under the Contract, include all constructional plant, providing safety at site, adequate arrangement for dust suppression/control, labour, supervision, materials, erection, maintenance, insurance, profit, royalties, taxes and duties, together with all general risks, liabilities and obligations set out in the Contract.
- 7.4 When percentage rate tenders are invited, the Bill of Quantities will show in the bidding documents, the quantities and rates used for different items.
- 7.5 Unless it is specifically specified, Ordinary Portland Cement (OPC) Grade -43 will be used in all concrete items.
- 7.6 Materials such as cement, reinforcement steel, bitumen and emulsion should be procured from approved vendor list (first four vendors only) as indicated in NHAI office memorandum issued vide letter no. NHAI/TIC/PQ/2012-13/205 dated 19.10.2022.

Note: Any arithmetic errors will be corrected by the Employer.

Bill of Quantities for percentage rate bids

Note: - Bidder has to quote %age Above/Below or at par on-line at prescribed column/Row.

Sl. No.	Description of item (with brief specification and reference to book of specifications)	Quantity	Unit	Rate without GST		Amount
				In figures	In words	
	Other items as per attached BOQ in Excel Sheet					
Name of road: (Length-.... Km) Nagar Nigam, width of carriage way ... m.						
	Routine Maintenance** after completion of construction works (Lump-sum Amount for each year) For 1st year For 2nd year For 3rd Year For 4th Year For 5th Year	 0 % 10 % 20 % 30 % 40 %		 ----- ----- ----- ----- -----	 ----- ----- ----- ----- -----	
	Total				Rs.	

Name of road: (Length-... Km) Nagar Nigam, width of carriage way m.						
Routine Maintenance** after completion of construction works (Lump-sum Amount for each year Per Km.) For 1 st year For 2 nd year For 3 rd Year For 4 th Year For 5 th Year						
	0 %			-----	-----	
	10 %			-----	-----	
	20 %			-----	-----	
	30 %			-----	-----	
	40 %			-----	-----	
Total					Rs.	
Name of road: (Length-.... Km) Nagar Nigam, width of carriage way m.						
Routine Maintenance** after completion of construction works (Lump-sum Amount for each year Per Km.) For 1 st year For 2 nd year For 3 rd Year For 4 th Year For 5 th Year						
	0 %			-----	-----	
	10 %			-----	-----	
	20 %			-----	-----	
	30 %			-----	-----	
	40 %			-----	-----	
Total					Rs.	

** The amount for each year should be pre-specified by the Authority and the figure inserted here before inviting the Bid. Routine maintenance rates are exclusive of GST. Employer to fill in the amount for maintenance in rate column only.

(Signature)

Notes:

1. The Schedule of Rate is Estimated rate quoted in the BoQ.
2. Wherever there is any discrepancy between the rate entered in the Bill of Quantities and the Schedule of Rates as per Note 1 above, the rate given in the Schedule of Rates will apply.
3. For Routine Maintenance, the amount indicated by the Authority shall apply. The Bidder is required to accept these rates. Further, the payment shall be performance based.

THIS PAGE HAS BEEN INTENTIONALLY KEPT BLANK

SECTION 8:- SECURITIES AND OTHER FORMS

BID SECURITY BANK GUARANTEE

To be paid online while submitting the bid

UNDERTAKING

I, the undersigned do hereby undertake that our firm M/s _____
agree to abide by this bid for a period _____
days for the date fixed for receiving the same and it shall be binding on us and may be accepted
at any time before the expiration of that period.

(Signed by an Authorised Officer of the Firm)

Title of Officer

Name of Firm

DATE

PERFORMANCE BANK GUARANTEE

To,

[name of Employer]
[address of Employer]

WHEREAS, [name and address of Contractor] (hereafter called "the Contractor") has undertaken, in pursuance of Contract No. dated to execute [name of Contract and brief description of Works] (hereinafter called "the Contract").

AND WHEREAS, it has been stipulated by you in the said Contract that the Contractor shall furnish you with a Bank Guarantee by a recognized bank for the sum specified therein as security for compliance with his obligation in accordance with the Contract;

AND WHEREAS, we have agreed to give the Contractor such a Bank Guarantee: NOW THEREFORE, we hereby affirm that we are the Guarantor and responsible to you on behalf of the Contractor, up to a total of [amount of guarantee]* (in words), such sum being payable in the types and proportions of currencies in which the Contract Price is payable, and we undertake to pay you, upon your first written demand and without cavil or argument, any sum or sums within the limits of [amount of guarantee] as aforesaid without your needing to prove or to show grounds or reasons for your demand for the sum specified therein.

We hereby waive the necessity of your demanding the said debt from the contractor before presenting us with the demand.

We further agree that no change or addition to or other modification of the terms of the Contract or of the Works to be performed thereunder or of any of the Contract documents which may be made between your and the Contractor shall in any way release us from any liability under this guarantee, and we hereby waive notice of any such change, addition or modification.

This guarantee shall be valid until 28 days from the date of expiry of the Defect Liability Period.

Signature and Seal of the guarantor
Name of Bank
Address
Date

-
- * An amount shall be inserted by the Guarantor, representing the percentage the Contract Price specified in the Contract including additional security for unbalanced Bids, if any and denominated in Indian Rupees.

BANK GUARANTEE FOR ADVANCE PAYMENT

To,

[name of the Employer]

[address of the Employer]

[name of the Contractor]

Gentlemen:

In accordance with the provisions of the Conditions of Contract, sub-clause 51.1 ("Advance Payment") of the above-mentioned Contract, [name and address of Contractor] (hereinafter called "the Contractor") shall deposit with[name of Employer] a bank guarantee to guarantee his proper and faithful performance under the said Clause of the Contract in an amount of [amount of Guarantee]* [in words].

We, the [bank of financial institution, as instructed by the Contractor, agree unconditionally and irrevocably to guarantee as primary obligator and not as Surety merely, the payment to [name of the Employer] on his first demand without whatsoever right of obligation on our part and without his first claim to the Contractor, in the amount not exceeding [amount of guarantee]* [in words].

We further agree that no change or addition to or other modification of the terms of the Contractor or Works to be performed thereunder or of any of the Contract documents which may be made between [name of Employer] and the Contractor, shall in any way release us from any liability under this guarantee, and we hereby waive notice of any such change, addition or modification.

This guarantee shall remain valid and in full effect from the date of the advance payment under the Contract until [name of Employer] receives full repayment of the same amount from the Contractor.

Yours truly,

Signature and Seal:

Name of Bank / Financial Institution:

Address:

Date: _____

-
- * An amount shall be inserted by the Bank or Financial Institution representing the amount of the Advance Payment, and denominated in Indian Rupees.

**INDENTURE FOR SECURED ADVANCES
FORM 31**

Deleted

OFFICE OF THE MUNICIPAL COMMISSIONER
KANPUR MUNICIPAL CORPORATION

AREA - Motijheel , Kanpur

NO.....

DATED

(a) LETTER OF ACCEPTANCE

To,

M/s

.....

.....

This is to notify you that on behalf of the Govt of UP, the Municipal Commissioner/ Chief Engineer/ Designated authority ----- has accepted your Bid dated ----- for execution of the Work for Nagar Nigam _____ for District

1.		Name of Work:	
or	Name of Road	Block	Length (Km.)
From		To	
1			

for the contract Price of Rs..... (In wordsonly) is hereby accepted by our Agency.

You are hereby requested to furnish Performance Security, in the form detailed in Cl.31 of C for an amount of Rs..... (in words) duly pledged in favour of under signed within 10 days of the receipt of this letter of acceptance valid up to 45 days from the date of expiry of Defects Liability Period (i.e. up to) and sign the contract, failing which action as stated in Cl. 31.3 of ITB will be taken.

You are also requested to submit the work programme, List of Tools and Plants to be brought to site, Name of technical personnel to be deployed at site, Name of borrow pits in case of Earth filling by cartage earth, Name of quarry from where the stone will be brought to site.

Yours faithfully,

Municipal Commissioner

Letter of Acceptance

(Letterhead paper of the Employer)

(Date)

To

(Name and address of the Contractor)

Dear Sirs,

This is to notify you that your Bid dated _____ for execution of the _____ (name of the contract and identification number, as given in the Instructions to Bidders) for the Contract Price of Rupees _____ (_____) (amount in words and figures), as corrected and modified in accordance with the Instructions to Bidders¹ is hereby accepted by our agency.

We accept / do not accept that _____ be appointed as the Adju-dicator². You are hereby requested to furnish Performance Security, in the form detailed in Para 34.1 of ITB for an amount equivalent to Rs. _____ within 21 days of the receipt of this letter of acceptance valid up to 28 days from the date of expiry of defects Liability Period i.e. up to _____ and sign the contract, failing which action as stated in Para 34.3 of ITB will be taken.

Yours faithfully,

Authorized Signature
Name and title of Signatory
Name of Agency

Delete "corrected and" or "and modified" if only one of these actions applies. Delete as corrected and modified in accordance with the Instructions to Bidders, if corrections or modifications have not been affected.

- ² To be used only if the Contractor disagrees in his Bid with the Adjudicator proposed by the Employer in the "Instructions to Bidders".

Issue of Notice to proceed with the work
(Letterhead of the Employer)

(Date)

To

(Name and address of the Contractor)

Dear Sirs,

Pursuant to your furnishing the requisite security as stipulated in ITB Clause 34.1 and signing of the Contract for the construction of

_____ at a Bid Price of Rs. _____ .

You are hereby instructed to proceed with the execution of the said works in accordance with the contract documents.

Yours faithfully,

(Signature, name and title of signatory
authorized to sign on behalf of Employer)

Agreement Form

Agreement

This agreement, made the _____ day of _____ between

_____ (name and address of Employer) [hereinafter called "the Employer] and _____ (name and address of contractor) hereinafter called "the Contractor" of the other part.

Whereas the Employer is desirous that the Contractor execute

_____ (name and identification number of Contract) (hereinafter called "the Works") and the Employer has accepted the Bid by the Contractor for the execution and completion of such Works and the remedying of any defects therein, at a cost of Rs. _____

NOW THIS AGREEMENT WITNESSETH as follows:

1. In this Agreement, words and expression shall have the same meanings as are respectively assigned to them in the conditions of contract hereinafter referred to and they shall be deemed to form and be read and construed as part of this Agreement.
2. In consideration of the payments to be made by the Employer to the Contractor as hereinafter mentioned, the Contractor hereby covenants with the Employer to execute and complete the Works and remedy any defects therein in conformity in all aspects with the provisions of the contract.

- i) Letter of Acceptance
- ii) Notice to proceed with the works;
- iii) Contractor's Bid
- iv) Condition of Contract: General and Special
- v) Contract Data
- vi) Additional condition
- vii) Drawings
- viii) Bill of Quantities and
- ix) Any other documents listed in the Contract Data as forming part of the Contract.

3. The Employer hereby covenants to pay the Contractor in consideration of the execution and completion of the Works and the remedying the defects wherein Contract Price or such other sum as may become payable under the provisions of the Contract at the times and in the manner prescribed by the Contract.

4. The following documents shall be deemed to form and be ready and construed as part of this Agreement viz.

In witnessed whereof the parties there to have caused this Agreement to be executed the day and year first before written.

The Common Seal of
was hereinto affixed in the presence of:

Signed, Sealed and Delivered by the said

in the presence of:

Binding Signature of Employer _____

Binding Signature of Contractor _____

THIS PAGE HAS BEEN INTENTIONALLY KEPT BLANK

SECTION 9:- DRAWINGS

THIS PAGE HAS BEEN INTENTIONALLY KEPT BLANK

SECTION 10:- DOCUMENTS TO BE FURNISHED BY BIDDER

EXISTING SECTION AA'

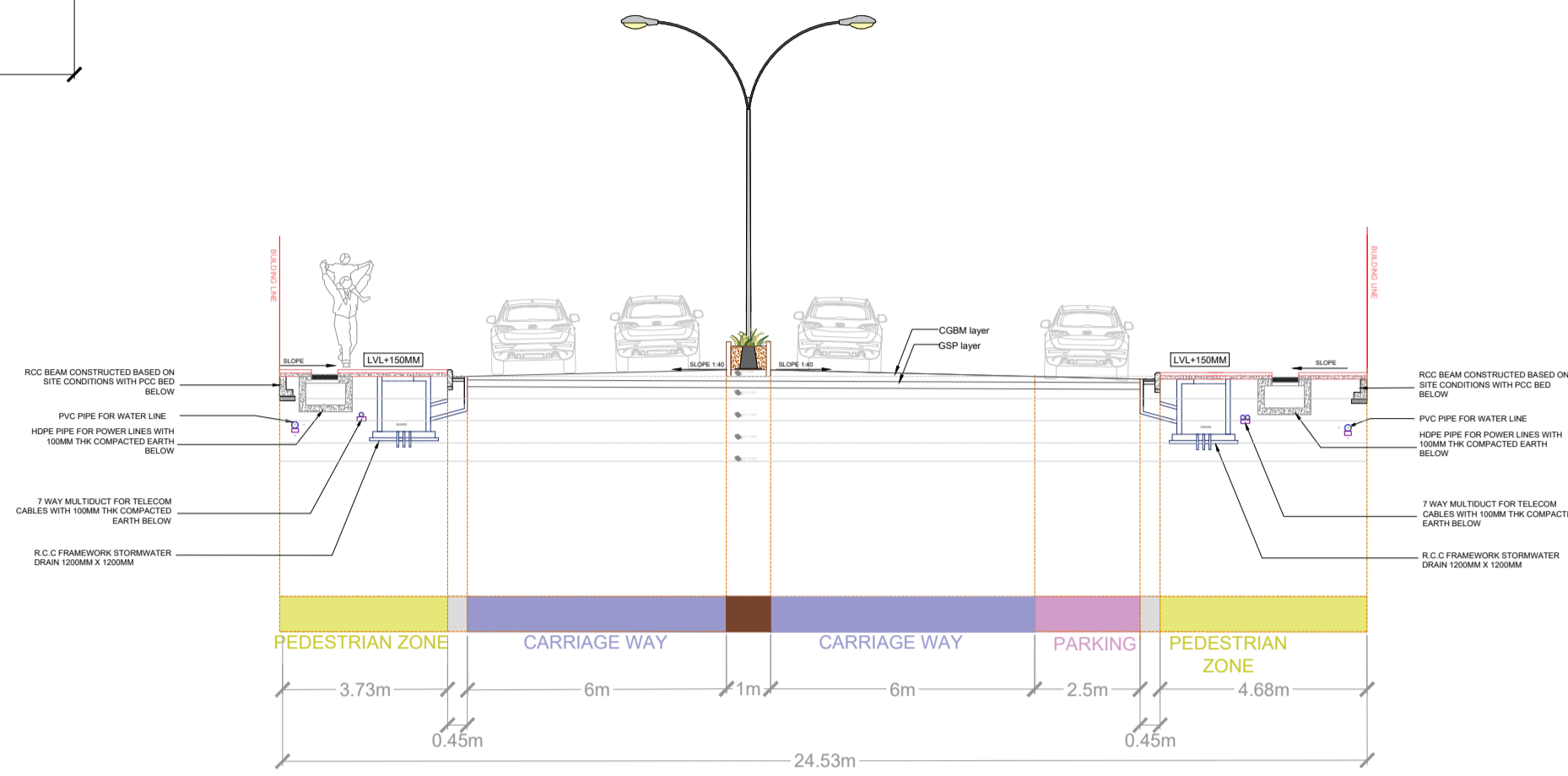
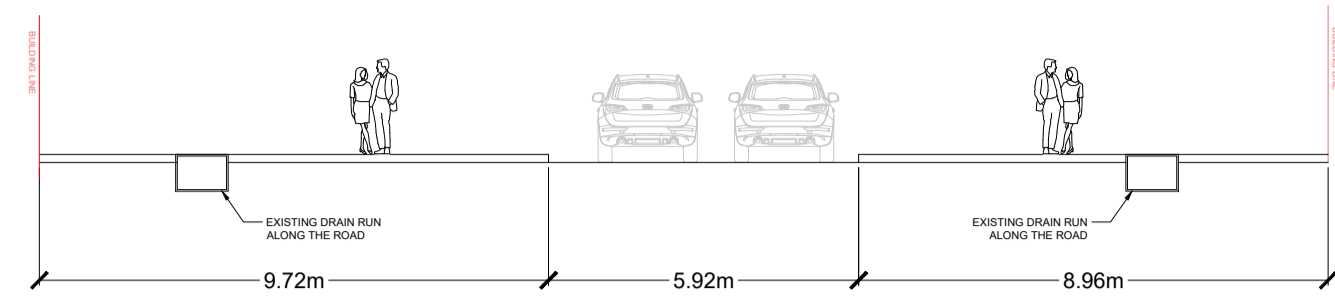

PROPOSED SECTION AA'

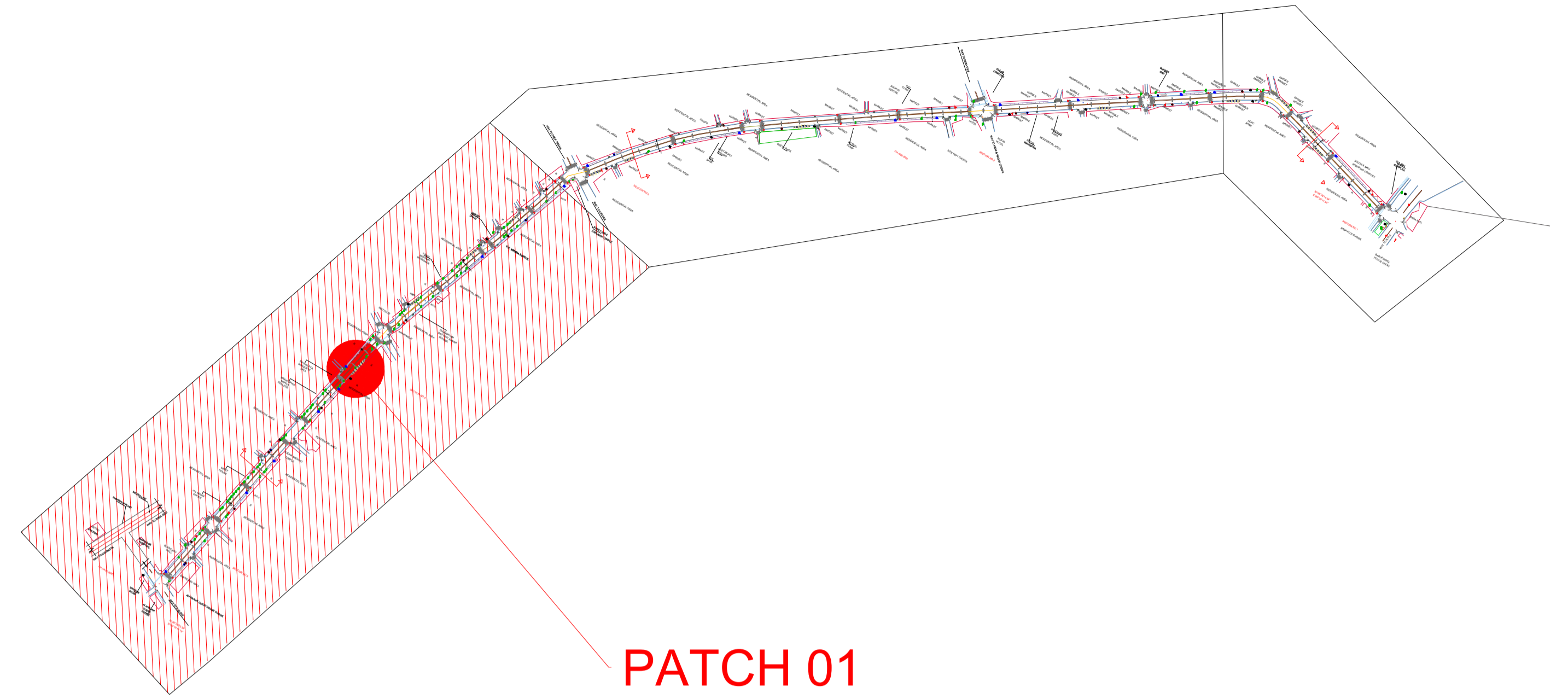

KEY PLAN OF MASTER PLAN

PROPOSED PLAN



LEGENDS	
1.	PROPOSED ROAD
2.	PROPOSED MEDIAN
3.	PROPOSED TABLE TOP

PROJECT:
CM GRID PROJECT, KANPUR, UP.

DRAWING RELEASED FOR

APPROVAL SUBMISSION
 ADVANCE COPY CONSTRUCTION

REVISION

S.N.	DATE	DESCRIPTIONS	INITIAL
1.			
2.			

CONSTRUCTION AGENCY :

STRUCTURAL CONSULTANTS :

MEP CONSULTANTS :

DRAWING TITLE:
PROPOSAL PLAN- BABA KUTI TO ALANKAR GUEST HOUSE

ORIENTATION

DEALT BY :
Ar. Aditi Sarsawat

CHECKED BY:

ARCHITECT:
Ar. A.R.KHAN

SHEET No.
PATCH 01

DATE:

SCALE:

AIMAN CONSULTANTS
A Group Of Architects & Interior Designers
14/113, Near Munshi Puliya Metro Station,
Indira Nagar, LUCKNOW, 226016
email : aiman.consultants@gmail.com

EXISTING SECTION BB'

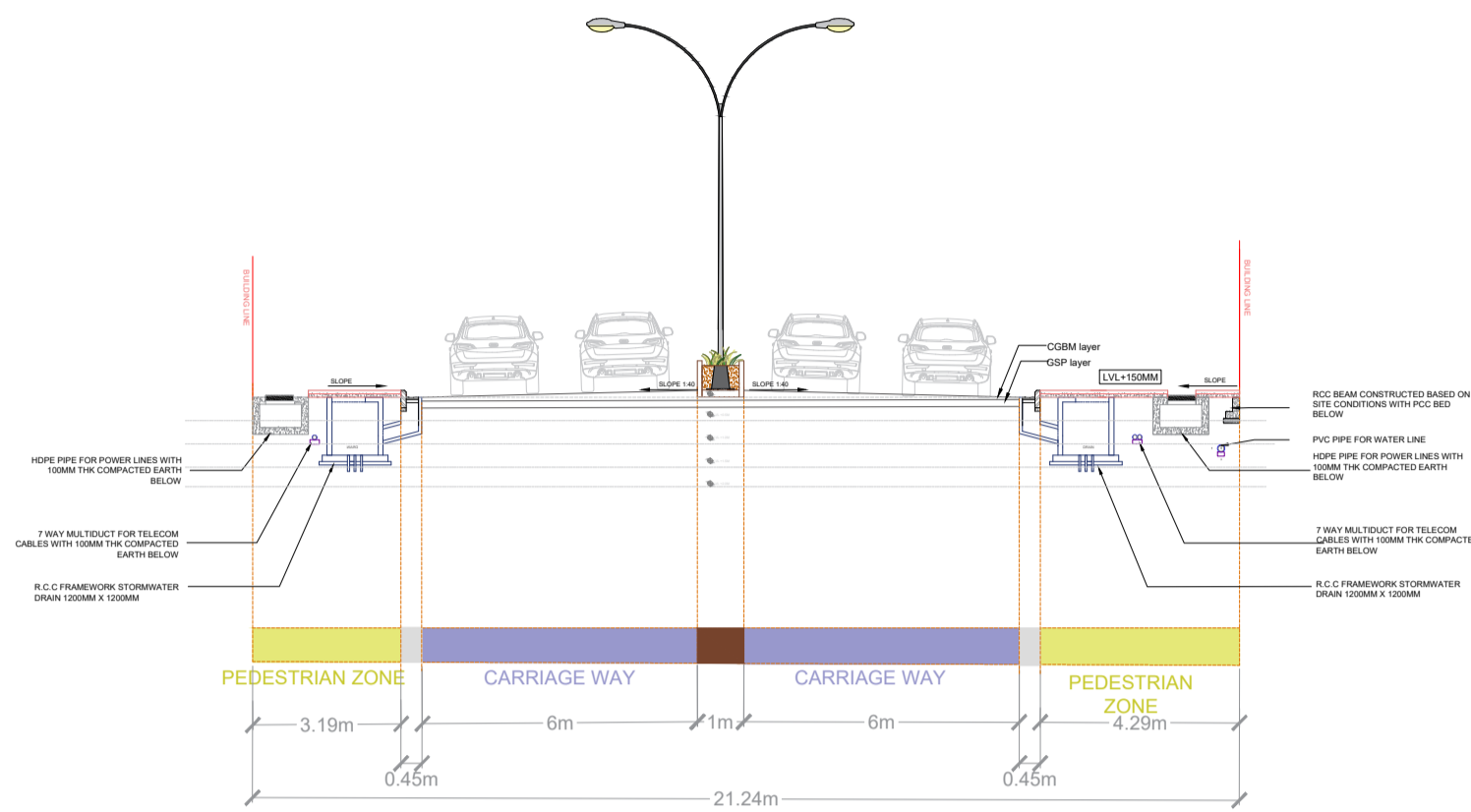
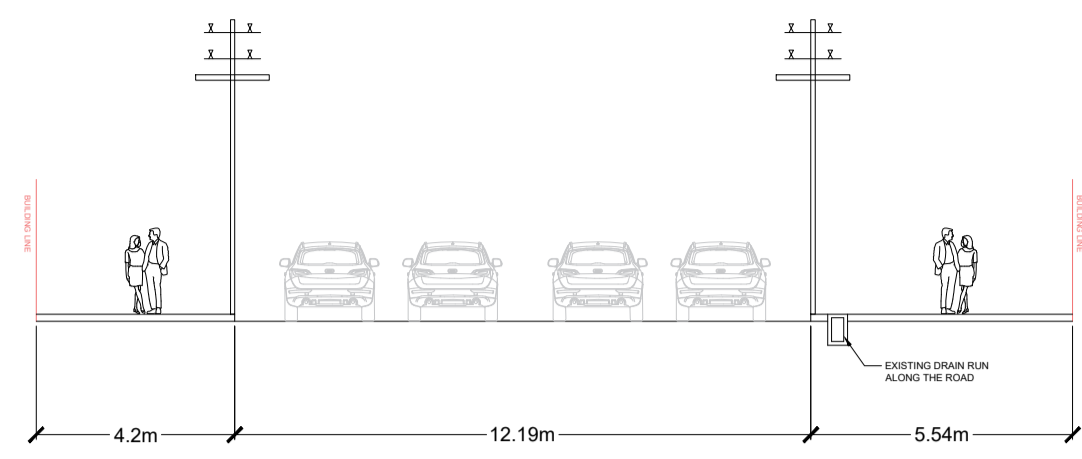

PROPOSED SECTION BB'

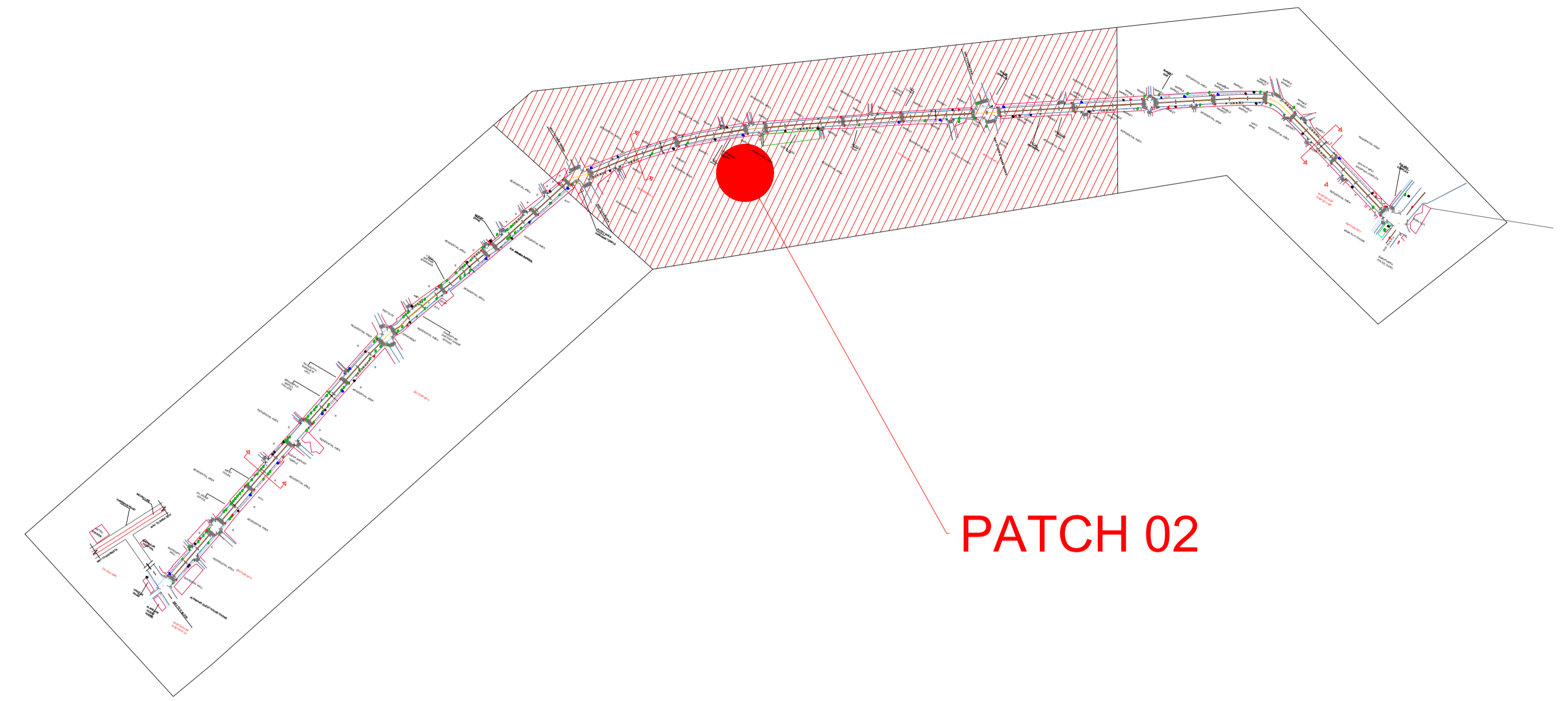

KEY PLAN OF MASTER PLAN

PROPOSED PLAN

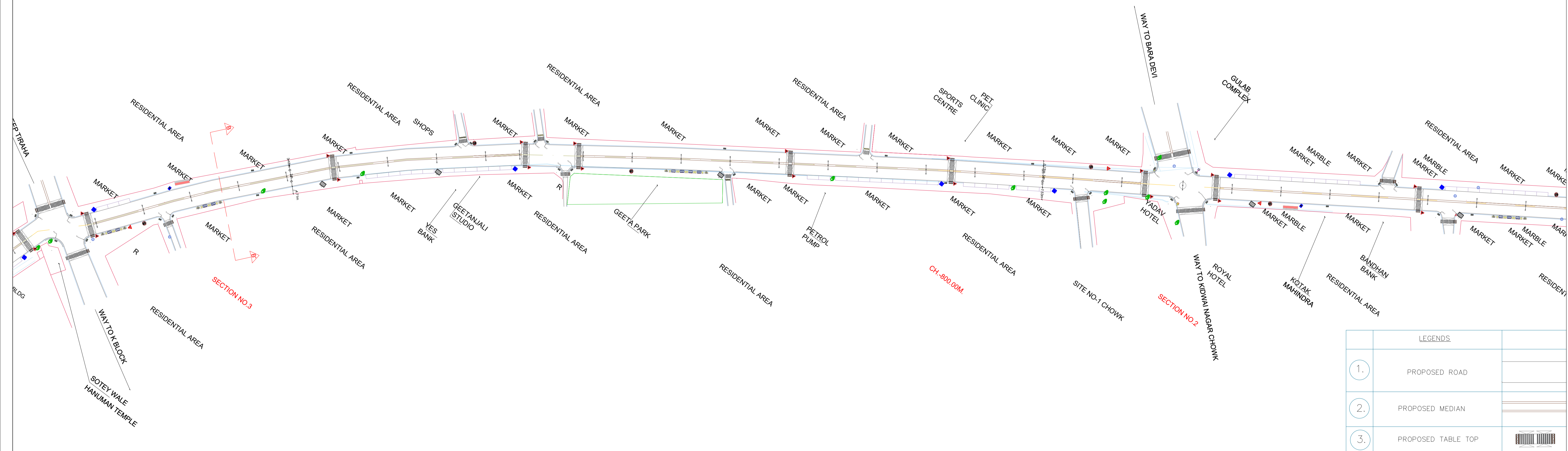

LEGENDS	
1.	PROPOSED ROAD
2.	PROPOSED MEDIAN
3.	PROPOSED TABLE TOP

PROJECT:
**CM GRID PROJECT,
KANPUR, UP.**

DRAWING RELEASED FOR
 APPROVAL SUBMISSION
 ADVANCE COPY CONSTRUCTION

REVISION

S.N.	DATE	DESCRIPTIONS	INITIAL
1.			
2.			

CONSTRUCTION AGENCY :
STRUCTURAL CONSULTANTS :
MEP CONSULTANTS :

DRAWING TITLE:
PROPOSAL PLAN- BABA KUTI TO ALANKAR GUEST HOUSE
SHEET No.
PATCH 02

ORIENTATION

DEALT BY :
Ar. Aditi Sarsawat
CHECKED BY:
ARCHITECT:
Ar. A.R.KHAN

DATE:
SCALE:

AIMAN CONSULTANTS
A Group Of Architects & Interior Designers
14/113, Near Munshi Puliya Metro Station,
Indira Nagar, LUCKNOW, 226016
email : aiman.consultants@gmail.com

EXISTING SECTION CC'

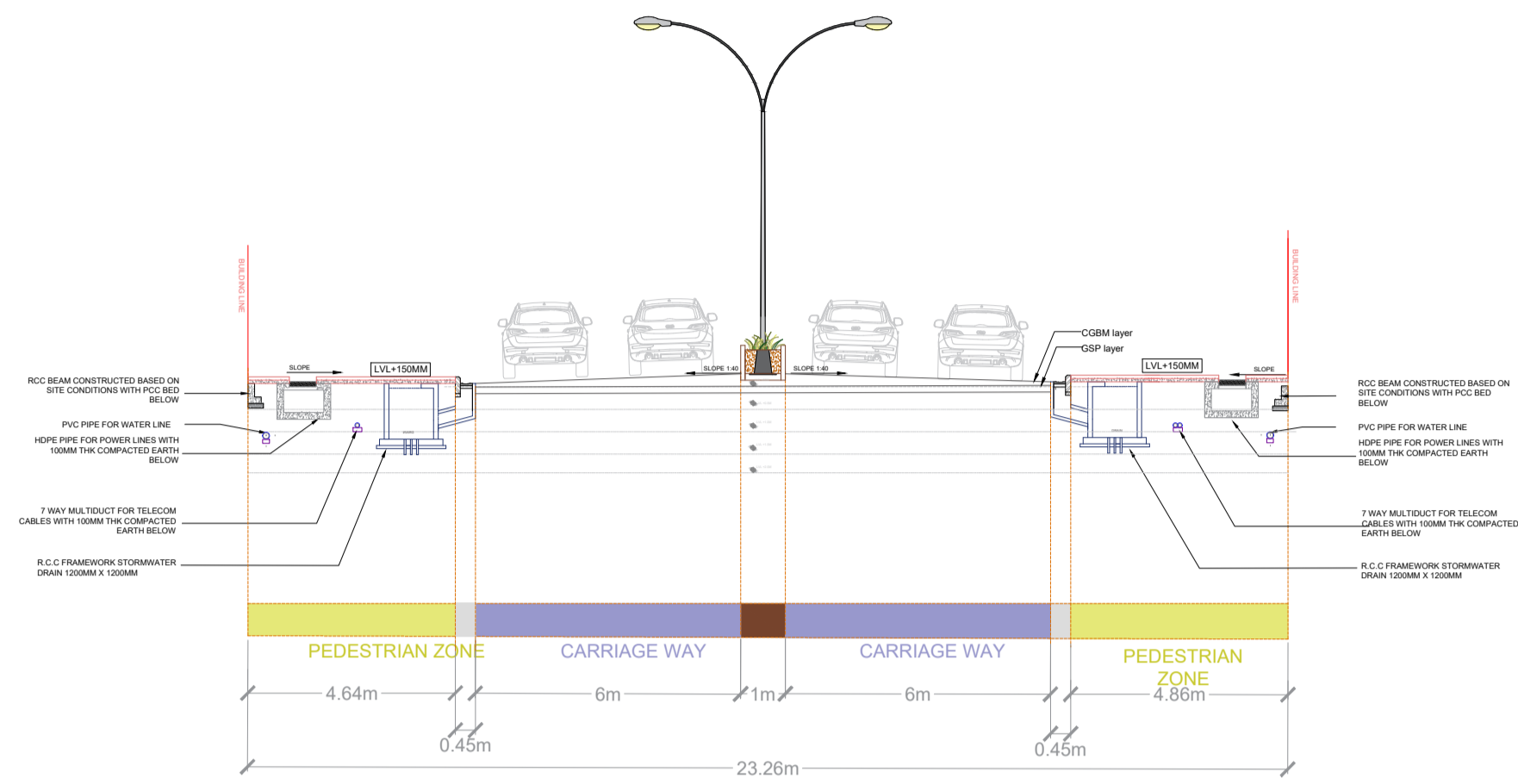
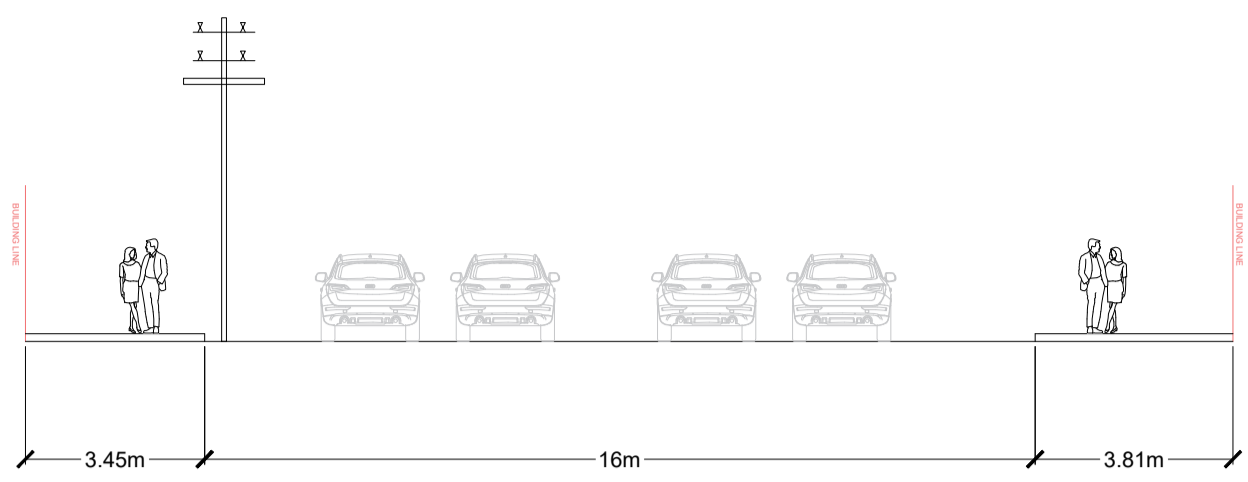

PROPOSED SECTION CC'

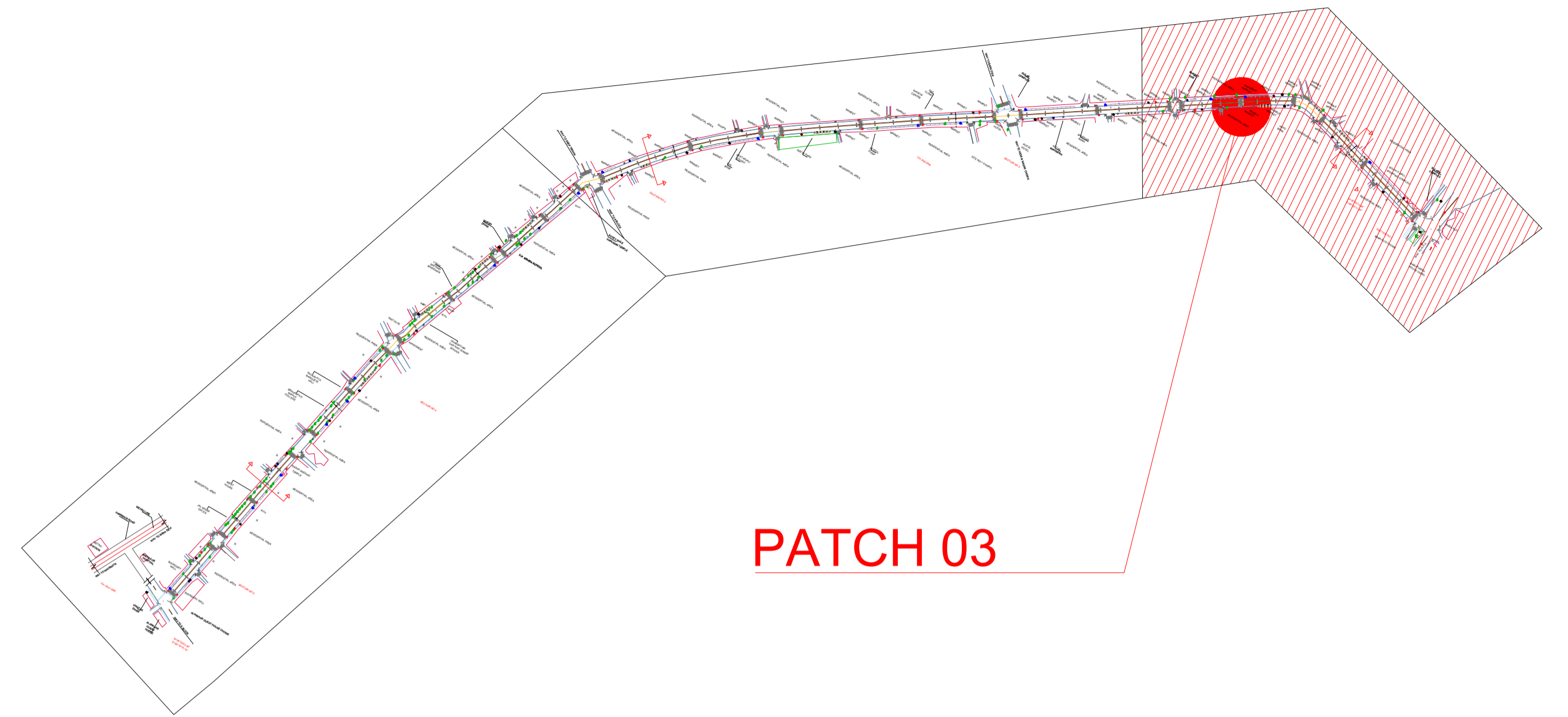

PATCH 03

KEY PLAN OF MASTER PLAN

PROPOSED PLAN

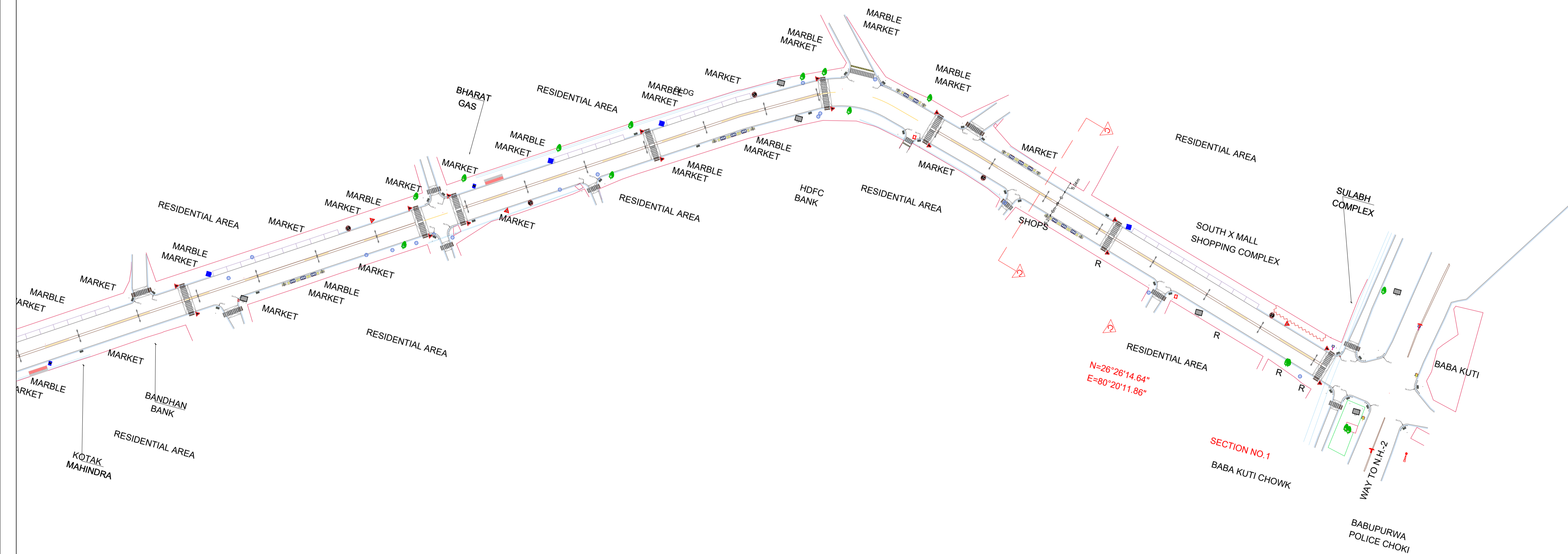

LEGENDS	
1.	PROPOSED ROAD
2.	PROPOSED MEDIAN
3.	PROPOSED TABLE TOP

<p>PROJECT:</p> <p>CM GRID PROJECT, KANPUR, UP.</p>	<p>DRAWING RELEASED FOR</p> <p><input type="checkbox"/> APPROVAL <input type="checkbox"/> SUBMISSION</p> <p><input type="checkbox"/> ADVANCE COPY <input type="checkbox"/> CONSTRUCTION</p>	<p>CONSTRUCTION AGENCY :</p>	<p>DRAWING TITLE:</p> <p>PROPOSAL PLAN- BABA KUTI TO ALANKAR GUEST HOUSE</p>	<p>ORIENTATION</p>	<p>DEALT BY :</p> <p>Ar. Aditi Sarsawat</p>	<p>DATE:</p>													
	<p>REVISION</p> <table border="1" style="width:100%; border-collapse: collapse;"> <thead> <tr> <th>S.N.</th> <th>DATE</th> <th>DESCRIPTIONS</th> <th>INITIAL</th> </tr> </thead> <tbody> <tr> <td>1.</td> <td></td> <td></td> <td></td> </tr> <tr> <td>2.</td> <td></td> <td></td> <td></td> </tr> </tbody> </table>	S.N.	DATE	DESCRIPTIONS	INITIAL	1.				2.				<p>STRUCTURAL CONSULTANTS :</p>	<p>SHEET No.</p> <p style="text-align: center; border: 1px solid black; padding: 2px;">PATCH 03</p>	<p>CHECKED BY:</p>	<p>SCALE:</p>	<p>ARCHITECT:</p> <p>Ar. A.R.KHAN</p>	
	S.N.	DATE	DESCRIPTIONS	INITIAL															
1.																			
2.																			
<p>MEP CONSULTANTS :</p>						<div style="text-align: center;"> <p>AIMAN CONSULTANTS A Group Of Architects & Interior Designers</p> <p>14/113, Near Munshi Puliya Metro Station, Indira Nagar, LUCKNOW, 226016 email : aiman.consultants@gmail.com</p> </div>													